

1 Series

WOOD FURNITURE STEM

Capacity up to **75 lbs each**



www.ColsonCaster.com
 Consult factory for RoHS and NSF requirements on a part specific basis.

RoHS Compliant
 ENVIRONMENTALLY FRIENDLY

NSF COMPONENT



Standard Dimensions*

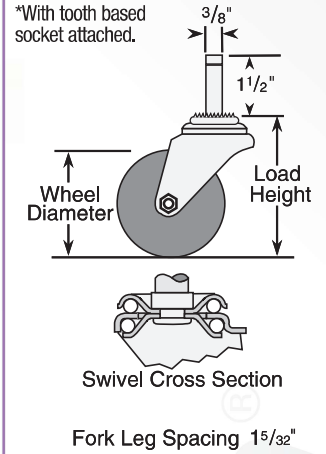

Features

- Zinc plated finish is attractive and durable
- Full double ball hardened raceways for better performance and greater durability
- 5/16" shouldered axle with 1/4" nut
- "Colson 45" multi-temp grease lubricates in extreme hot and cold temperatures

Standard Mounting

- For use on wood furniture that can accept a 3/8" diameter hole approximately 1 5/8" deep
- **Stem Size:** 5/16" diameter x 1 1/2" long grip neck
- Standard No. 20 pressed steel adapter (Part #50011) with toothed base is supplied

Colson 1 Series Casters • Wood Furniture Stem • Capacity to 75 lbs

Wheel Dia.	Tread Width	Capacity Each (Pounds)	Wheel Descriptions	Wheel Bearing	Stem Caster Models	Load Height	Swivel Radius	Weight (Pounds)
1 ⁵ / ₈ "	7/8"	60	Performa Rubber	Delrin	1.01652.441	2 ¹ / ₂ "	1 ³ / ₄ "	1/2
		75	Polyolefin	Delrin	1.01652.52	2 ¹ / ₂ "	1 ³ / ₄ "	1/2
2"	7/8"	75	Performa Rubber	Delrin	1.02252.441	2 ¹ / ₁₆ "	1 ¹⁵ / ₁₆ "	1/2
			Polyolefin	Delrin	1.02252.52	2 ¹ / ₁₆ "	1 ¹⁵ / ₁₆ "	1/2
			Cushion Rubber	Ball	1.02252.45	2 ¹ / ₁₆ "	1 ¹⁵ / ₁₆ "	1/2
			Hard Rubber	Ball	1.02252.55	2 ¹ / ₁₆ "	1 ¹⁵ / ₁₆ "	1/2
3"	7/8"	75	Performa Rubber	Delrin	1.03052.441	3 ¹³ / ₁₆ "	2 ⁹ / ₁₆ "	3/4
			Polyurethane HI-TECH	Delrin	1.03052.91	3 ¹³ / ₁₆ "	2 ⁹ / ₁₆ "	3/4
			Polyolefin	Delrin	1.03052.53	3 ¹³ / ₁₆ "	2 ⁹ / ₁₆ "	3/4

Caster Brake



Side Lock
 (See page 86) Available on all 3" models. Field installable (Specify **BRK3**; Example: 1.03052.53 BRK3).

Fork Options

NSF Listed For Food Service Industry
 Consult factory for details.

Forks Only
 To order caster forks only use 1st 6 digits of model numbers (Example: 1.01652).

Wheel Selection



See the Performa Advantage on Page 55.

Wheel Option

Thread Guards
 (See page 98) Available on all 3" models. Brake & NSF options cannot be used with thread guards (Specify **TG1** for metal; Example: 1.01652.441 TG1).

www.ColsonCaster.com
Consult factory for RoHS and NSF requirements on a part specific basis.



1 Series

EXPANDING ADAPTER STEM

Capacity up to **145 lbs each**



Standard Dimensions

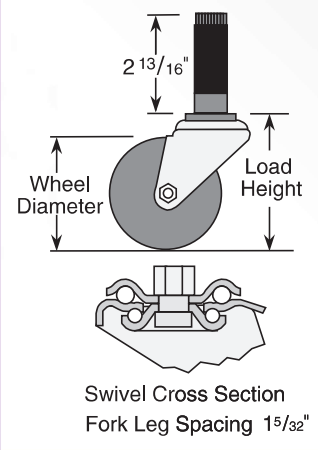

Features

- Zinc plated finish is attractive and durable
- Full double ball hardened raceways for better performance and greater durability
- 5/16" shouldered axle with 1/4" nut
- "Colson 45" multi-temp grease lubricates in extreme hot and cold temperatures

Standard Mounting

- Turning of octagon on upper raceway expands rubber adapter inside of round or square tubing for a tight, permanent fit
- To order, select caster model number and specify stem adapter size by code number from mounting options chart at bottom right

Colson 1 Series Casters • Expanding Adapter Stem • Capacity to 145 lbs each

Wheel Dia.	Tread Width	Capacity Each (Pounds)	Wheel Descriptions	Wheel Bearing	Stem Caster Models*	Load Height	Swivel Radius	Weight (Pounds)
3"	7/8"	100	Polyurethane HI-TECH	Delrin	1.03367.91	37/8"	213/16"	11/4
		125	Performa Rubber	Delrin	1.03367.441	37/8"	213/16"	11/4
			Polyolefin	Delrin	1.03367.53	37/8"	213/16"	11/4
4"	7/8"	125	Polyurethane HI-TECH	Delrin	1.04367.91	47/8"	37/16"	11/2
		135	Performa Rubber	Delrin	1.04367.441	47/8"	37/16"	11/2
			Polyolefin	Delrin	1.04367.53	47/8"	37/16"	11/2
5"	7/8"	140	Polyurethane HI-TECH	Delrin	1.05367.91	57/8"	41/16"	13/4
		145	Performa Rubber	Delrin	1.05367.441	57/8"	41/16"	13/4
			Polyolefin	Delrin	1.05367.53	57/8"	41/16"	13/4

*To order you must include mounting code in the Mounting Options chart below (Example: 1.03367.91 MTG40).

Note: Expanding adapter temperature rating is 180°F.

Caster Brake



Side Lock (See page 86)
Available on all models. Field installable (Specify **BRK3**; Example: 1.03367.91 BRK3).

Fork Options

NSF Listed For Food Service Industry
Consult factory for details.

Forks Only
To order caster forks only use 1st 6 digits of model numbers (Example: 1.03367).

Wheel Selection



See the Performa Advantage on Page 55.

Wheel Option

Thread Guards (See page 98) Available on all 3" models. Brake & NSF options cannot be used with thread guards (Specify **TG1** for metal; Example: 1.03367.91 TG1).

Mounting Options

(See page 97)

Inside Diameter of Tube	Mounting Code Numbers	
	Round Tubing	Square Tubing
3/4" - 13/16"	MTG40	-
7/8" - 15/16"	MTG41	MTG51
1" - 11/16"	MTG42	MTG52
1 1/8" - 13/16"	MTG43	MTG53
1 1/4" - 15/16"	MTG44	MTG54
1 3/8" - 17/16"	MTG45	MTG55
1 1/2" - 19/16"	MTG46	-
1 5/8" - 111/16"	MTG47	-

Stems are 211/16" long. Stem size less adapter: 1/2" - 13UNC x 213/16"

To order add the mounting code to Stem Caster Models number (Example: 1.03367.91 MTG40).

3D CAD Models & Data Sheets
www.colsoncaster.com/casters

Colson 1 Series

1 Series

Capacity up to 75 lbs each

GRIP RING STEM



www.ColsonCaster.com
Consult factory for RoHS and NSF requirements on a part specific basis.

RoHS COMPLIANT ENVIRONMENTALLY FRIENDLY

NSF COMPONENT



Standard Dimensions

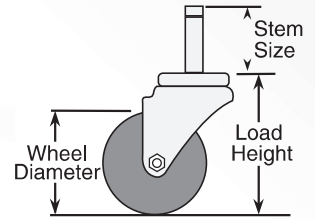

Swivel Cross Section
Fork Leg Spacing 1⁵/₃₂"

Features

- Zinc plated finish is attractive and durable
- Full double ball hardened raceways for better performance and greater durability
- 5/16" shouldered axle with 1/4" nut
- "Colson 45" multi-temp grease lubricates in extreme hot and cold temperatures

Standard Mounting

- Spring grip on top of stem holds caster firmly in place
- **Stem Size:** 7/16" x 1²⁹/₃₂" long with grip ring

Colson 1 Series Casters • Grip Ring Stem • Capacity to 75 lbs each

Wheel Dia.	Tread Width	Capacity Each (Pounds)	Wheel Descriptions	Wheel Bearing	Stem Caster Models	Load Height	Swivel Radius	Weight (Pounds)
1 ⁵ / ₈ "	7/8"	60	Performa Rubber	Delrin	1.01651.441	2 ¹ / ₂ "	1 ³ / ₄ "	1/2
		75	Polyolefin	Delrin	1.01651.52	2 ¹ / ₂ "	1 ³ / ₄ "	1/2
2"	7/8"	75	Performa Rubber	Delrin	1.02251.441	2 ¹¹ / ₁₆ "	1 ¹⁵ / ₁₆ "	1/2
			Polyolefin	Delrin	1.02251.52	2 ¹¹ / ₁₆ "	1 ¹⁵ / ₁₆ "	1/2
			Cushion Rubber	Ball	1.02251.45	2 ¹¹ / ₁₆ "	1 ¹⁵ / ₁₆ "	5/8
			Hard Rubber	Ball	1.02251.55	2 ¹¹ / ₁₆ "	1 ¹⁵ / ₁₆ "	5/8
3"	7/8"	75	Performa Rubber	Delrin	1.03051.441	3 ¹³ / ₁₆ "	2 ⁹ / ₁₆ "	3/4
			Polyurethane HI-TECH	Delrin	1.03051.91	3 ¹³ / ₁₆ "	2 ⁹ / ₁₆ "	3/4
			Polyolefin	Delrin	1.03051.53	3 ¹³ / ₁₆ "	2 ⁹ / ₁₆ "	3/4

Caster Brake



Side Lock
(See page 86) Available on all 3" models. Field installable (Specify **BRK3**; Example: 1.03051.53 BRK3).

Fork Options

NSF Listed For Food Service Industry
Consult factory for details.

Forks Only

To order caster forks only use 1st 6 digits of model numbers (Example: 1.01651).

Wheel Selection



See the Performa Advantage on Page 55.

Wheel Option

Thread Guards

(See page 98) Available on all 3" models. Brake & NSF options cannot be used with thread guards (Specify **TG1** for metal; Example: 1.01651.441 TG1).

Mounting Options

Standard Mounting (no code necessary):
7/16" x 1²⁹/₃₂" long with grip ring.

MTG1: 3/8" x 1⁹/₁₆" long

MTG2: 7/16" x 1⁹/₁₆" long

MTG50: 7/16" x 1" long

MTG51: 7/16" x 1²⁹/₃₂" long less grip ring

MTG57: 1/2" x 4 1/2" (ladder caster stem)

To order optional mounting, add mounting code to Stem Caster Models number (Example: 1.01651.441 MTG1).

3D CAD Models & Data Sheets
www.colsoncaster.com/casters

www.ColsonCaster.com
Consult factory for RoHS and NSF requirements on a part specific basis.



1 Series

Capacity up to **145 lbs each**

GRIP RING STEM



Standard Dimensions

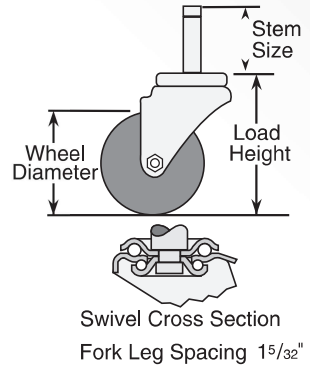

Features

- Zinc plated finish is attractive and durable
- Full double ball hardened raceways for better performance and greater durability
- 5/16" shouldered axle with 1/4" nut
- "Colson 45" multi-temp grease lubricates in extreme hot and cold temperatures

Standard Mounting

- Spring grip on top of stem holds caster firmly in place
- **Stem Size:** 7/16" x 1 29/32" long **with** grip ring

Colson 1 Series Casters • Grip Ring Stem • Capacity to 145 lbs each

Wheel Dia.	Tread Width	Capacity Each (Pounds)	Wheel Descriptions	Wheel Bearing	Stem Caster Models	Load Height	Swivel Radius	Weight (Pounds)
3"	7/8"	100	Polyurethane HI-TECH	Delrin	1.03351.91	3 ³ / ₄ "	2 ¹³ / ₁₆ "	1
		125	Performa Rubber	Delrin	1.03351.441	3 ³ / ₄ "	2 ¹³ / ₁₆ "	1 ¹ / ₈
			Polyolefin	Delrin	1.03351.53	3 ³ / ₄ "	2 ¹³ / ₁₆ "	1 ¹ / ₈
4"	7/8"	125	Polyurethane HI-TECH	Delrin	1.04351.91	4 ³ / ₄ "	3 ⁷ / ₁₆ "	1 ¹ / ₈
			Performa Rubber	Delrin	1.04351.441	4 ³ / ₄ "	3 ⁷ / ₁₆ "	1 ³ / ₈
			Polyolefin	Delrin	1.04351.53	4 ³ / ₄ "	3 ⁷ / ₁₆ "	1 ³ / ₈
5"	7/8"	140	Polyurethane HI-TECH	Delrin	1.05351.91	5 ³ / ₄ "	4 ¹ / ₁₆ "	1 ¹ / ₄
			Performa Rubber	Delrin	1.05351.441	5 ³ / ₄ "	4 ¹ / ₁₆ "	1 ⁵ / ₈
			Polyolefin	Delrin	1.05351.53	5 ³ / ₄ "	4 ¹ / ₁₆ "	1 ¹ / ₈

Caster Brake



Side Lock (See page 86)
Available on all models. Field installable (Specify **BRK3**; Example: 1.03351.91 BRK3).

Fork Options

NSF Listed For Food Service Industry
Consult factory for details.

Forks Only

To order caster forks only use 1st 6 digits of model numbers (Example: 1.03351).

Wheel Selection



Wheel Option

Thread Guards (See page 98) Available on all 3" models. Brake & NSF options cannot be used with thread guards (Specify **TG1** for metal; Example: 1.03351.91 TG1).

Mounting Options

Standard Mounting (no code necessary):
7/16" x 1 29/32" long **with** grip ring **no** plastic adapter.

MTG2: 7/16" x 1 1/2" long

MTG51: 7/16" x 1 29/32" long **less** grip ring

To order optional mounting, add mounting code to Stem Caster Model number (Example: 1.03367.91 MTG51).

Plastic Adapters

Snaps in place to reduce distortion and damage to furniture and equipment tubing.

Plastic adapters are non-conductive. To order, add plastic adapter mounting code from below to Stem Caster Model number (Example: 1.03351.91 MTG53).

MTG53: (No. 50810): Fits 7/8" x 18 ga. wall round tubing or any I.D. from 3/4" to 51/64".

MTG55: (No. 50865): Fits 1" x 14 ga. wall round tubing or any I.D. from 53/64" to 55/64".

MTG56: (No. 50916): Fits 1" x 16 ga. wall round tubing or any I.D. from 57/64" to 29/32".



3D CAD Models & Data Sheets
www.colsoncaster.com/casters

1 Series

1 Series

Capacity up to 75 lbs each

THREADED STEM



www.ColsonCaster.com
 Consult factory for RoHS and NSF requirements on a part specific basis.

RoHS Compliant
 ENVIRONMENTALLY FRIENDLY

NSF COMPONENT



Standard Dimensions

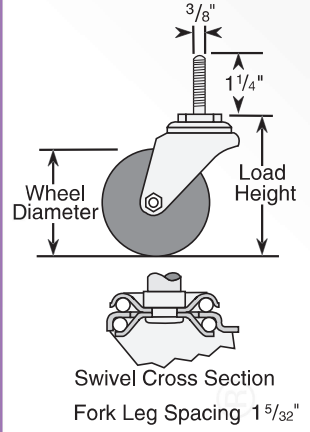

Features

- Zinc plated finish is attractive and durable
- Full double ball hardened raceways for better performance and greater durability
- 5/16" shouldered axle with 1/4" nut
- "Colson 45" multi-temp grease lubricates in extreme hot and cold temperatures

Standard Mounting

- **Stem Size:** 3/8" diameter - 16UNC x 1 1/4" long threaded 1 1/8"

IMPORTANT: If caster stem is to be screwed into customer equipment, the customer must add a washer to the stem that will cover the incomplete threads and support the upper race. The stem shoulder must fit tightly against the customer equipment.

Colson 1 Series Casters • Threaded Stem • Capacity to 75 lbs each

Wheel Dia.	Tread Width	Capacity Each (Pounds)	Wheel Descriptions	Wheel Bearing	Stem Caster Models	Load Height	Swivel Radius	Weight (Pounds)
1 5/8"	7/8"	60	Performa Rubber	Delrin	1.01654.441	2 1/2"	1 3/4"	3/8
		75	Polyolefin	Delrin	1.01654.52	2 1/2"	1 3/4"	3/8
2"	7/8"	75	Performa Rubber	Delrin	1.02254.441	2 11/16"	1 15/16"	3/8
			Polyolefin	Delrin	1.02254.52	2 11/16"	1 15/16"	3/8
			Cushion Rubber	Ball	1.02254.45	2 11/16"	1 15/16"	1/2
			Hard Rubber	Ball	1.02254.55	2 11/16"	1 15/16"	1/2
3"	7/8"	75	Performa Rubber	Delrin	1.03054.441	3 13/16"	2 9/16"	5/8
			Polyurethane HI-TECH	Delrin	1.03054.91	3 13/16"	2 9/16"	5/8
			Polyolefin	Delrin	1.03054.53	3 13/16"	2 9/16"	5/8

Caster Brake



Side Lock
 (See page 86) Available on all 3" models. Field installable (Specify **BRK3**; Example: 1.03054.53 BRK3).

Fork Options

NSF Listed For Food Service Industry
 Consult factory for details.

Forks Only

To order caster forks only use 1st 6 digits of model numbers (Example: 1.01654).

Wheel Selection



See the Performa Advantage on Page 55.

Wheel Option

Thread Guards

(See page 98) Available on all 3" models. Brake & NSF options cannot be used with thread guards (Specify **TG1** for metal; Example: 1.01654.441 TG1).

Mounting Options

Standard Mounting (no code necessary):
 3/8" diameter - 16UNC x 1 1/4" long threaded 1 1/8".

MTG51: 3/8" diameter - 24NF x 1 1/16" long

To order optional mounting, add mounting code to Stem Caster Models number (Example: 1.01654.441 MTG51).

3D CAD Models & Data Sheets
www.colsoncaster.com/casters

www.ColsonCaster.com
Consult factory for RoHS and NSF requirements on a part specific basis.



1 Series

Capacity up to **145 lbs each**

THREADED STEM



Standard Dimensions

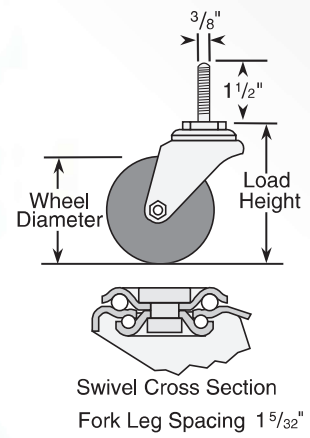

Features

- Zinc plated finish is attractive and durable
- Full double ball hardened raceways for better performance and greater durability
- 5/16" shouldered axle with 1/4" nut
- "Colson 45" multi-temp grease lubricates in extreme hot and cold temperatures

Standard Mounting

- **Stem Size:** 3/8" diameter - 16UNC x 1 1/2" long threaded 1 3/8"

IMPORTANT: If caster stem is to be screwed into customer equipment, the customer must add a washer to the stem that will cover the incomplete threads and support the upper race. The stem shoulder must fit tightly against the customer equipment.

Colson 1 Series Casters • Threaded Stem • Capacity to 145 lbs each

Wheel Dia.	Tread Width	Capacity Each (Pounds)	Wheel Descriptions	Wheel Bearing	Stem Caster Models	Load Height	Swivel Radius	Weight (Pounds)
3"	7/8"	100	Polyurethane HI-TECH	Delrin	1.03354.91	33/4"	213/16"	11/8
		125	Performa Rubber	Delrin	1.03354.441	33/4"	213/16"	11/8
			Polyolefin	Delrin	1.03354.53	33/4"	213/16"	11/8
4"	7/8"	125	Polyurethane HI-TECH	Delrin	1.04354.91	43/4"	37/16"	13/8
		135	Performa Rubber	Delrin	1.04354.441	43/4"	37/16"	13/8
			Polyolefin	Delrin	1.04354.53	43/4"	37/16"	13/8
5"	7/8"	140	Polyurethane HI-TECH	Delrin	1.05354.91	53/4"	41/16"	15/8
		145	Performa Rubber	Delrin	1.05354.441	53/4"	41/16"	15/8
			Polyolefin	Delrin	1.05354.53	53/4"	41/16"	15/8

Caster Brake



Side Lock (See page 86)
Available on all models. Field installable (Specify **BRK3**; Example: 1.03354.91 BRK3).

Fork Options

NSF Listed For Food Service Industry
Consult factory for details.

Forks Only
To order caster forks only use 1st 6 digits of model numbers (Example: 1.03354).

Wheel Selection



See the Performa Advantage on Page 55.

Wheel Option

Thread Guards
(See page 98) Available on all 3" models. Brake & NSF options cannot be used with thread guards (Specify **TG1** for metal; Example: 1.03354.91 TG1).

3D CAD Models & Data Sheets
www.colsoncaster.com/casters

1 Series



1 Series

Capacity up to 145 lbs each

SQUARE STEM



Standard Dimensions

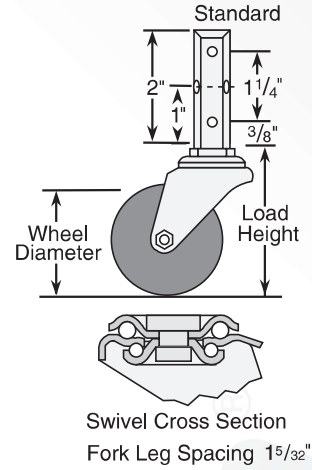

Features

- Zinc plated finish is attractive and durable
- Full double ball hardened raceways for better performance and greater durability
- 5/16" shouldered axle with 1/4" nut
- "Colson 45" multi-temp grease lubricates in extreme hot and cold temperatures

Standard Mounting

- Designed for easy installation on the inside of angle iron legs or against flat surfaces
- Stems may be bolted or riveted against any flat vertical surface
- **Stem Size:** 2" long x 3/4" square with 3 mounting holes 17/64" diameter

Colson 1 Series Casters • Square Stem • Capacity to 145 lbs each

Wheel Dia.	Tread Width	Capacity Each (Pounds)	Wheel Descriptions	Wheel Bearing	Stem Caster Models	Load Height	Swivel Radius	Weight (Pounds)
3"	7/8"	100	Polyurethane HI-TECH	Delrin	1.03370.91	3 3/4"	2 13/16"	1 1/4
		125	Performa Rubber	Delrin	1.03370.441	3 3/4"	2 13/16"	1 1/4
			Polyolefin	Delrin	1.03370.53	3 3/4"	2 13/16"	1 1/4
4"	7/8"	125	Polyurethane HI-TECH	Delrin	1.04370.91	4 3/4"	3 7/16"	1 1/2
		135	Performa Rubber	Delrin	1.04370.441	4 3/4"	3 7/16"	1 1/2
			Polyolefin	Delrin	1.04370.53	4 3/4"	3 7/16"	1 1/2
5"	7/8"	140	Polyurethane HI-TECH	Delrin	1.05370.91	5 3/4"	4 1/16"	1 3/4
		145	Performa Rubber	Delrin	1.05370.441	5 3/4"	4 1/16"	1 3/4
			Polyolefin	Delrin	1.05370.53	5 3/4"	4 1/16"	1 3/4

Caster Brake



Side Lock
 (See page 86) Available on all models. Field installable (Specify **BRK3**; Example: 1.03370.441 BRK3).

Fork Options

NSF Listed For Food Service Industry
 Consult factory for details.

Forks Only

To order caster forks only use 1st 6 digits of model numbers (Example: 1.03370).

Wheel Selection

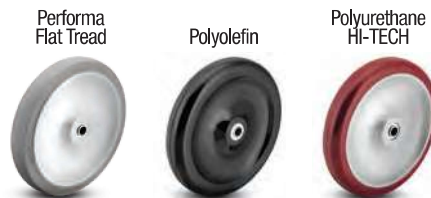

See the Performa Advantage on Page 55.

Wheel Option

Thread Guards

(See page 98) Available on all 3" models. Brake & NSF options cannot be used with thread guards (Specify **TG1** for metal; Example: 1.03370.91 TG1).

Mounting Options

Standard Mounting (no code necessary):
 2" long x 3/4" square with 3 mounting holes 17/64" diameter.

MTG1: Optional Square Stem:
 2" long x 7/8" square with 1 mounting hole 17/64" diameter.

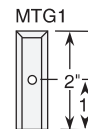

To order optional mounting, add mounting code above to Stem Caster Models number (Example: 1.03370.91 MTG1).

1 Series

Capacity up to 75 lbs each

SMALL TOP PLATE Swivel & Rigid

www.ColsonCaster.com
Consult factory for RoHS and NSF requirements on a part specific basis.



Standard Dimensions

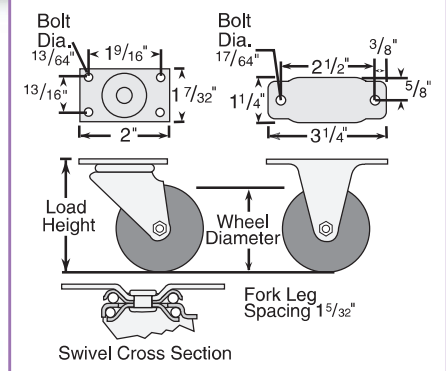

Features

- Zinc plated finish is attractive and durable
- Full double ball hardened raceways for better performance and greater durability
- 5/16" shouldered axle with 1/4" nut
- "Colson 45" multi-temp grease lubricates in extreme hot and cold temperatures

Standard Mounting

- Rigid caster mounting holes do not match swivel

Colson 1 Series Casters • Small Top Plate Swivel and Rigid • Capacity to 75 lbs each

Wheel Dia.	Tread Width	Capacity Each (Pounds)	Wheel Descriptions	Wheel Bearing	Swivel Top Plate Caster Models	Rigid Top Plate Caster Models	Load Height	Swivel Radius	Weight (Pounds)
1 5/8"	7/8"	60	Performa Rubber	Delrin	1.01666.441	1.01610.441	29/16"	13/4"	3/8
		75	Polyolefin	Delrin	1.01666.52	1.01610.52	29/16"	13/4"	3/8
2"	7/8"	75	Performa Rubber	Delrin	1.02266.441	1.02210.441	23/4"	115/16"	1/2
			Polyolefin	Delrin	1.02266.52	1.02210.52	23/4"	115/16"	1/2
			Cushion Rubber	Ball	1.02266.45	1.02210.45	23/4"	115/16"	1/2
			Hard Rubber	Ball	1.02266.55	1.02210.55	23/4"	115/16"	1/2
3"	7/8"	75	Performa Rubber	Delrin	1.03066.441	—	37/8"	29/16"	3/4
			Polyurethane HI-TECH	Delrin	1.03066.91	—	37/8"	29/16"	3/4
			Polyolefin	Delrin	1.03066.53	—	37/8"	29/16"	3/4

Caster Brake



Side Lock (See page 86)
Available on all 3" swivel models. Field installable (Specify **BRK3**; Example: 1.03066.91 BRK3).

Fork Options

NSF Listed For Food Service Industry
Consult factory for details.

Forks Only
To order caster forks only use 1st 6 digits of model numbers (Example: 1.01666).

Wheel Selection



See the Performa Advantage on Page 55.

Wheel Option

Thread Guards
(See page 98) Available on all 3" models. Brake & NSF options cannot be used with thread guards (Specify **TG1** for metal; Example: 1.01666.441 TG1).

1 Series

Capacity up to **75 lbs each**

TOP PLATE Swivel & Rigid

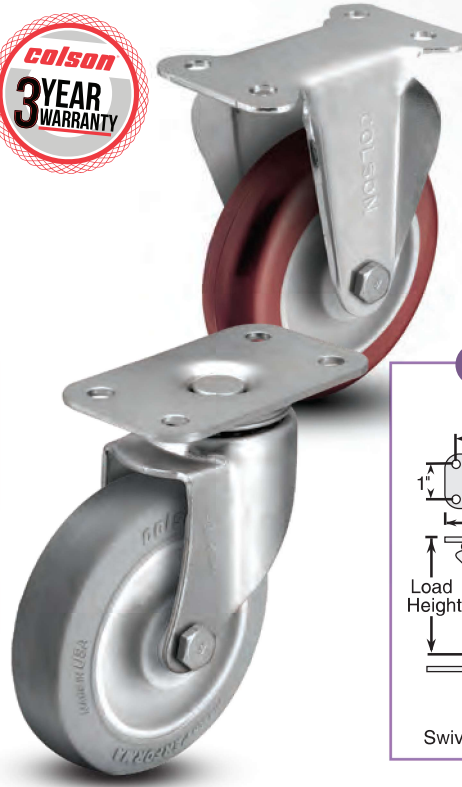

Standard Dimensions

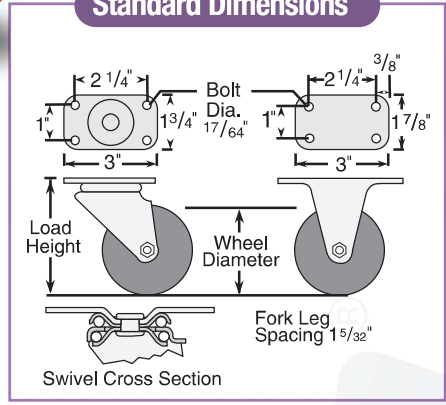

Features

- Zinc plated finish is attractive and durable
- Full double ball hardened raceways for better performance and greater durability
- 5/16" shouldered axle with 1/4" nut
- "Colson 45" multi-temp grease lubricates in extreme hot and cold temperatures

Standard Mounting

- Rigid caster available with 3" diameter wheel only

Colson 1 Series Casters • Top Plate Swivel and Rigid • Capacity to 75 lbs each

Wheel Dia.	Tread Width	Capacity Each (Pounds)	Wheel Descriptions	Wheel Bearing	Swivel Top Plate Caster Models	Rigid Top Plate Caster Models	Load Height	Swivel Radius	Weight (Pounds)
1 5/8"	7/8"	60	Performa Rubber	Delrin	1.01656.441	—	29/16"	13/4"	1/2
		75	Polyolefin	Delrin	1.01656.52	—	29/16"	13/4"	1/2
2"	7/8"	75	Performa Rubber	Delrin	1.02256.441	—	23/4"	115/16"	1/2
			Polyolefin	Delrin	1.02256.52	—	23/4"	115/16"	1/2
			Cushion Rubber	Ball	1.02256.45	—	23/4"	115/16"	5/8
			Hard Rubber	Ball	1.02256.55	—	23/4"	115/16"	5/8
3"	7/8"	75	Performa Rubber	Delrin	1.03056.441	1.03010.441	37/8"	29/16"	3/4
			Polyurethane HI-TECH	Delrin	1.03056.91	1.03010.91	37/8"	29/16"	3/4
			Polyolefin	Delrin	1.03056.53	1.03010.53	37/8"	29/16"	3/4

Caster Brake



Side Lock
(See page 86) Available on all 3" swivel models. Field installable (Specify **BRK3**; Example: 1.03056.53 BRK3).

Fork Option

NSF Listed For Food Service Industry
Consult factory for details.

Forks Only
To order caster forks only use 1st 6 digits of model numbers (Example: 1.01656).

Wheel Selection



See the Performa Advantage on Page 55.

Wheel Option

Thread Guards
(See page 98) Available on all 3" models. Brake & NSF options cannot be used with thread guards (Specify **TG1** for metal; Example: 1.01656.441 TG1).

1 Series

LARGE TOP PLATE Swivel & Rigid
Capacity up to **145 lbs each**



www.ColsonCaster.com
Consult factory for RoHS and NSF requirements on a part specific basis.



Features

- Zinc plated finish is attractive and durable
- Full double ball hardened raceways for better performance and greater durability
- 5/16" shouldered axle with 1/4" nut
- .090" steel top plate
- "Colson 45" multi-temp grease lubricates in extreme hot and cold temperatures

Standard Dimensions

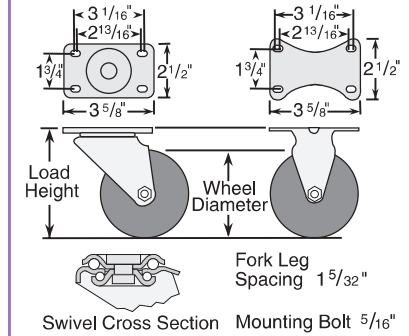

Colson 1 Series Casters • Large Top Plate Swivel and Rigid • Capacity to 145 lbs each

Wheel Dia.	Tread Width	Capacity Each (Pounds)	Wheel Descriptions	Wheel Bearing	Swivel Top Plate Caster Models	Rigid Top Plate Caster Models	Load Height	Swivel Radius	Weight (Pounds)
3"	7/8"	100	Polyurethane HI-TECH	Delrin	1.03356.91	1.03008.91	3 3/4"	2 13/16"	1 1/4
		125	Performa Rubber	Delrin	1.03356.441	1.03008.441	3 3/4"	2 13/16"	1 1/4
			Polyolefin	Delrin	1.03356.53	1.03008.53	3 3/4"	2 13/16"	1 1/4
4"	7/8"	125	Polyurethane HI-TECH	Delrin	1.04356.91	1.04008.91	4 3/4"	3 7/16"	1 1/2
		135	Performa Rubber	Delrin	1.04356.441	1.04008.441	4 3/4"	3 7/16"	1 1/2
			Polyolefin	Delrin	1.04356.53	1.04008.53	4 3/4"	3 7/16"	1 1/2
5"	7/8"	140	Polyurethane HI-TECH	Delrin	1.05356.91	1.05008.91	5 3/4"	4 1/16"	1 3/4
		145	Performa Rubber	Delrin	1.05356.441	1.05008.441	5 3/4"	4 1/16"	1 3/4
			Polyolefin	Delrin	1.05356.53	1.05008.53	5 3/4"	4 1/16"	1 3/4

Caster Brake



Side Lock
(See page 86) Available on all swivel models. Field installable (Specify **BRK3**; Example: 1.03356.91 BRK3).

Fork Option

NSF Listed For Food Service Industry
Consult factory for details.

Forks Only

To order caster forks only use 1st 6 digits of model numbers (Example: 1.03356).

Wheel Selection



See the Performa Advantage on Page 55.

Wheel Option

Thread Guards

(See page 98) Available on all 3" models. Brake & NSF options cannot be used with thread guards (Specify **TG1** for metal; Example: 1.03356.91 TG1).

3D CAD Models & Data Sheets
www.colsoncaster.com/casters

1 Series

