

# 2 Series

Capacity up to **350 lbs each**

**TOP PLATE** Swivel & Rigid



Consult factory for RoHS requirements on a part specific basis.

Consult the NSF listing page on a part specific basis for NSF requirements.

## Features

- Zinc plated finish is attractive and durable
- Full double ball hardened raceways for better performance and greater durability
- 3/8" hollow axle with lock nut
- Grease holes on wheel bearing for greater convenience
- "Colson 45" multi-temp grease lubricates in extreme hot and cold temperatures



## Standard Dimensions

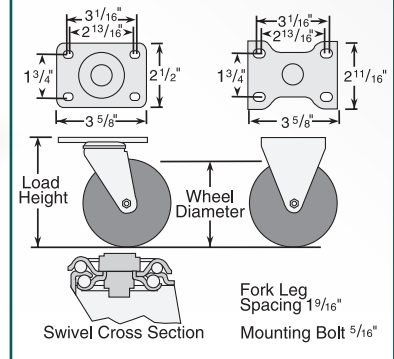

## Caster Brake



**Top Lock**  
(See page 86) Available on all swivel models with solid axle only. Field installable (Specify **BRK1**; Example: 2.05256.91 BRK1).



**Posi Lock**  
(See page 87) Available on all swivels. Field installable (Specify **BRK8**; Example: 2.05256.319 BRK8).



**Total Lock**  
(See page 86) Locks wheel and swivel simultaneously. Fits 3", 3 1/2", 4", 5" and 6" swivel models. Field installable (Specify **BRK5**; Example: 2.05256.53 BRK5).



**Directional Lock**  
(See page 87) Available with standard top plate only. For optional top plates, consult factory. To order with caster, change 4th digit to "1" (Example: 2.05156.91).

Note: No Dust Cap Available.

## Fork Option

**NSF Listed For Food Service Industry**  
Consult factory for details.

**Swivel Dust Cap**  
(See page 90) (Specify **DC1** standard; **DC2** Dust Cap w/ grease seal and zerk) Example: 2.05256.441 **DC2**).

**Forks Only**  
To order caster forks only use 1st 6 digits of model numbers (Example: 2.05256).

**Axle/Nut Options** Consult factory.

## Wheel Selection

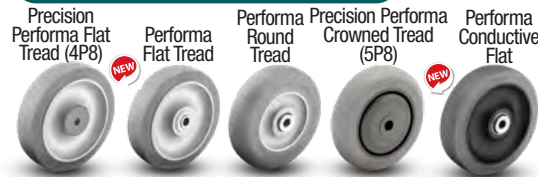

See the Performa Advantage on Page 55.



## Wheel Options

**Standard Thread Guards**  
Full thread guards are standard on Precision Polyurethane HI-TECH (9P8) and Performa Crowned Tread (5P8). Partial Thread Guards are standard on Precision Performa Rubber Flat Tread models (4P8).

**Optional Thread Guards**  
(See page 98) Available on many models. Specify **TG1** for metal or **TG2** for plastic; Example: 2.05256.441 TG2.

## Optional Top Plates

**# 27 Top Plate (Swivel)**  
(Specify **MTG27**)

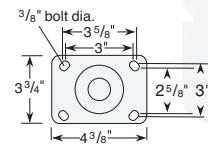

**# 35 Top Plate (Swivel)**  
(Specify **MTG35**)

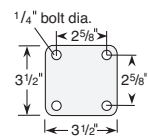

**# 59 Top Plate (Swivel)**  
(Specify **MTG59**).

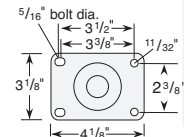

To order optional top plate, add mounting code to Swivel Top Plate Caster Models number (Example: 2.02256.445 MTG27).

**Prevenz™ Antimicrobial for Medical and Food Service Industries.** This caster wheel additive inhibits the growth of harmful microbes, including bacteria, mold, and fungi. Available for Precision Performa Flat/Crowned and Precision Polyurethane HI-Tech. To order, add "PREV" to the caster number. Example: 2.05256.9P8 PREV.



**3D CAD Models & Data Sheets**  
www.colsoncaster.com/casters

**Colson 2 Series Casters • Top Plate Swivel & Rigid • Capacity to 350 lbs**

Wheel Dia.	Tread Width	Capacity Each (Pounds)	Wheel Descriptions	Standard Bearings	Swivel Caster Models	Rigid Caster Models	Optional Bearings	Load Height	Swivel Radius	Weight (Pounds)	
2 1/2"	1 1/4"	125	Performa Flat Conductive	Ball	2.02256.445COND	2.02208.445COND	—	3 7/8"	2 13/32"	1 5/8	
		140	Performa Flat	Ball	2.02256.445	2.02208.445	Delrin (441)	3 7/8"	2 13/32"	1 5/8	
		200	Polyolefin	Ball	2.02256.55	2.02208.55	Delrin (53)	3 7/8"	2 13/32"	1 5/8	
		250	Polyurethane Hi-Tech Maroon	Ball	2.02256.95	2.02208.95	Delrin (91)	3 7/8"	2 13/32"	1 5/8	
		250	Polyurethane Hi-Tech Grey	Ball	2.02256.95G	2.02208.95G	Delrin (91G)	3 7/8"	2 13/32"	1 5/8	
	300	Cast Iron	Plain	2.02256.12	2.02208.12	—	—	3 7/8"	2 13/32"	2	
	1 7/16"	300	Phenolic	Roller	2.02256.319	2.02208.319	—	3 7/8"	2 13/32"	2	
3"	1 1/4"	150	Soft Rubber	Plain	2.03356.RR2	2.03308.RR2	—	3 11/16"	2 29/32"	2 1/4	
		200	Polyolefin	Ball	2.03356.55	2.03308.55	Delrin (52)	4 1/8"	2 21/32"	2	
		200	Performa Flat	Ball	2.03356.445	2.03308.445	Delrin (441)	4 1/8"	2 21/32"	2	
		200	Precision Performa Flat	Precision Ball	2.03356.4P8	2.03308.4P8	—	4 1/8"	2 21/32"	2	
		200	Performa Crown	Precision Ball	2.03356.5P8	2.03308.5P8	—	4 1/8"	2 21/32"	2	
		200	Performa Flat Conductive	Ball	2.03356.445COND	2.03308.445COND	—	4 1/8"	2 21/32"	2	
		200	Polyolefin	Ball	2.03356.55	2.03308.55	Delrin (52)	4 1/8"	2 21/32"	2	
		300	Polyurethane Hi-Tech Maroon	Ball	2.03356.95	2.03308.95	Delrin (91)	4 1/8"	2 21/32"	2	
		300	Polyurethane Hi-Tech Grey	Ball	2.03356.95G	2.03308.95G	Delrin (91G)	4 1/8"	2 21/32"	2	
		300	Precision Polyurethane Hi-Tech Grey	Precision Ball	2.03356.9P8	2.03308.9P8	—	4 1/8"	2 21/32"	2	
		300	K Solid Polyurethane	Plain	2.03356.KK2	2.03308.KK2	—	4 1/8"	2 21/32"	2	
		300	Cast Iron	Plain	2.03356.14	2.03308.14	—	4 1/8"	2 21/32"	2 3/4	
		1 15/32"	350	Hard Rubber	Plain	2.03356.RN2	2.03308.RN2	—	3 11/16"	2 29/32"	2 1/4
			350	Phenolic	Roller	2.03356.309	2.03308.309	—	4 1/8"	2 21/32"	2 3/4
3 1/2"	1 1/4"	150	Soft Rubber	Plain	2.03256.RR2	2.03208.RR2	—	4 11/16"	2 29/32"	2 1/4	
		250	Performa Flat	Ball	2.03256.445	2.03208.445	Delrin (441)	4 11/16"	2 29/32"	2	
		250	Performa Flat Conductive	Ball	2.03256.445COND	2.03208.445COND	—	4 11/16"	2 29/32"	2	
		250	Precision Performa Flat	Precision Ball	2.03256.4P8	2.03208.4P8	—	4 11/16"	2 29/32"	2	
		250	Performa Crown	Precision Ball	2.03256.5P8	2.03208.5P8	—	4 11/16"	2 29/32"	2 1/4	
		250	Performa Round	Ball	2.03256.565	2.03208.565	Delrin (561)	4 11/16"	2 29/32"	2 1/4	
	1 5/16"	250	Performa Round Conductive	Ball	2.03256.565COND	2.03208.565COND	—	4 11/16"	2 29/32"	2	
		280	Polyolefin	Ball	2.03256.55	2.03208.55	Delrin (53)	4 11/16"	2 29/32"	1 7/8	
		300	Thermo	Plain	2.03256.52HT	2.03208.52HT	—	4 11/16"	2 29/32"	2 7/8	
		300	Cast Iron	Plain	2.03256.12	2.03208.12	—	4 11/16"	2 29/32"	3	
		1 1/4"	350	Phenolic	Roller	2.03256.309	2.03208.309	—	4 11/16"	2 29/32"	3
			350	Hard Rubber	Plain	2.03256.RN2	2.03208.RN2	—	4 11/16"	2 29/32"	2 1/4
			350	Polyurethane Hi-Tech Maroon	Ball	2.03256.95	2.03208.95	Delrin (91)	4 11/16"	2 29/32"	2
			350	Polyurethane Hi-Tech Grey	Ball	2.03256.95G	2.03208.95G	Delrin (91G)	4 11/16"	2 29/32"	1 7/8
350	Precision Polyurethane Hi-Tech Grey		Precision Ball	2.03256.9P8	2.03208.9P8	—	4 11/16"	2 29/32"	1 7/8		
			150	Soft Rubber	Plain	2.04256.RR2	2.04208.RR2	—	5 1/8"	3 29/32"	2 1/4
4"	1 1/4"	300	Performa Flat	Ball	2.04256.445	2.04208.445	Delrin (441)	5 1/8"	3 29/32"	2 1/4	
		300	Performa Flat Conductive	Ball	2.04256.445COND	2.04208.445COND	—	5 1/8"	3 29/32"	2 1/4	
		300	Precision Performa Flat	Precision Ball	2.04256.4P8	2.04208.4P8	—	5 1/8"	3 29/32"	2 1/4	
		300	Performa Crown	Precision Ball	2.04256.5P8	2.04208.5P8	—	5 1/8"	3 29/32"	2 1/4	
		300	Thermo	Plain	2.04256.52HT	2.04208.52HT	—	5 1/8"	3 29/32"	3 1/8	
		300	Cast Iron	Plain	2.04256.12	2.04208.12	—	5 1/8"	3 29/32"	3 3/8	
		350	Polyolefin	Ball	2.04256.55	2.04208.55	Delrin (53)	5 1/8"	3 29/32"	2 1/8	
		350	Polyurethane Hi-Tech Maroon	Ball	2.04256.95	2.04208.95	Delrin (91)	5 1/8"	3 29/32"	2 1/8	
		350	Polyurethane Hi-Tech Grey	Ball	2.04256.95G	2.04208.95G	Delrin (91G)	5 1/8"	3 29/32"	2 1/8	
		350	Precision Polyurethane Hi-Tech Grey	Precision Ball	2.04256.9P8	2.04208.9P8	—	5 1/8"	3 29/32"	2 1/4	
		350	K Solid Polyurethane	Plain	2.04256.KK2	2.04208.KK2	—	5 1/8"	3 29/32"	2 1/4	
		350	Hard Rubber	Plain	2.04256.RN2	2.04208.RN2	—	5 1/8"	3 29/32"	2 1/4	
	350	Phenolic	Roller	2.04256.309	2.04208.309	—	5 1/8"	3 29/32"	3 3/8		
	5"	1 1/4"	175	Soft Rubber	Plain	2.05256.RR2	2.05208.RR2	—	6 3/16"	3 13/16"	3
300			Cast Iron	Plain	2.05256.12	2.05208.12	—	6 3/16"	3 13/16"	2 1/2	
325			Performa Flat	Ball	2.05256.445	2.05208.445	Delrin (441)	6 3/16"	3 13/16"	3 1/2	
325			Performa Flat Conductive	Ball	2.05256.445COND	2.05208.445COND	—	6 3/16"	3 13/16"	3	
325			Precision Performa Flat	Precision Ball	2.05256.445	2.05208.445	—	6 3/16"	3 13/16"	3 1/2	
325			Performa Crown	Precision Ball	2.05256.5P8	2.05208.5P8	—	6 3/16"	3 13/16"	2 3/4	
1 5/16"		325	Performa Round Conductive	Ball	2.05256.565COND	2.05208.565COND	—	6 3/16"	3 13/16"	3	
		325	Performa Round	Ball	2.05256.565	2.05208.565	Delrin (561)	6 3/16"	3 13/16"	3	
		350	Hard Rubber	Plain	2.05256.RN2	2.05208.RN2	—	6 3/16"	3 13/16"	3	
		350	Polyolefin	Ball	2.05256.55	2.05208.55	Delrin (53)	6 3/16"	3 13/16"	2 1/2	
		350	Polyurethane Hi-Tech Maroon	Ball	2.05256.95	2.05208.95	Delrin (91)	6 3/16"	3 13/16"	2 1/2	
		350	Polyurethane Hi-Tech Grey	Ball	2.05256.95G	2.05208.95G	Delrin (91G)	6 3/16"	3 13/16"	2 1/2	
		350	Precision Polyurethane Hi-Tech Grey	Precision Ball	2.05256.9P8	2.05208.9P8	—	6 3/16"	3 13/16"	2 1/2	
		350	K Solid Polyurethane	Plain	2.05256.KK2	2.05208.KK2	—	6 3/16"	3 13/16"	2 1/2	
1 1/4"	350	Thermo	Plain	2.05256.52HT	2.05208.52HT	—	6 3/16"	3 13/16"	3 3/4		
	350	Phenolic	Roller	2.05256.309	2.05208.309	—	6 3/16"	3 13/16"	3 3/4		
	6"	1 1/4"	350	Performa Flat	Ball	2.06256.445	2.06208.445	Delrin (441)	7 1/4"	4 5/16"	3 1/4
			350	Performa Flat Conductive	Ball	2.06256.445COND	2.06208.445COND	—	7 1/4"	4 5/16"	3 1/4
			350	Polyurethane Hi-Tech Maroon	Ball	2.06256.95	2.06208.95	Delrin (91)	7 1/4"	4 5/16"	2 7/8
			350	Polyurethane Hi-Tech Grey	Ball	2.06256.95G	2.06208.95G	Delrin (91G)	7 1/4"	4 5/16"	3 7/8
350			Polyolefin	Ball	2.06256.55	2.06208.55	Delrin (53)	7 1/4"	4 5/16"	2 7/8	

**2 Series**

# 2 Series

Capacity up to **350 lbs each**



Consult factory for RoHS requirements on a part specific basis.

Consult the NSF listing page on a part specific basis for NSF requirements.



## Features

- Zinc plated finish is attractive and durable
- Full double ball hardened raceways for better performance and greater durability
- 3/8" hollow axle with lock nut
- Grease holes on wheel bearing for greater convenience
- "Colson 45" multi-temp grease lubricates in extreme hot and cold temperatures

## Standard Mounting

- **Stem Size:** 1/2" diameter – 13UNC X 1 1/2" long, threaded 1 3/8"
- **Easy Installation:** The 7/16" hex nut beneath the lower raceway makes it fast and easy to install these casters on a wide variety of equipment

## Standard Dimensions

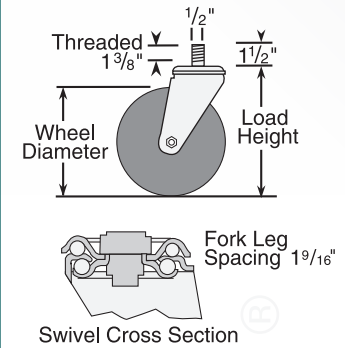

## Caster Brake



### Top Lock

(See page 86) Available on all swivel models with solid axle only. Field installable (Specify **BRK1**; Example: 2.05254.91 BRK1).



### Posi Lock

(See page 87) Available on all swivels. Field installable (Specify **BRK8**; Example: 2.05254.4P5 BRK8).



### Total Lock

(See page 86) Locks wheel and swivel simultaneously. Fits 3 1/2", 4" and 5" swivel models. Field installable (Specify **BRK5** Example: 2.05254.12 BRK5).

## Fork Option

**NSF Listed For Food Service Industry**  
Consult factory for details.

### Swivel Dust Cap

(See page 90) (Specify **DC1**; Example: 2.05254.441 DC1).

### Forks Only

To order caster forks only use 1st 6 digits of model numbers (Example: 2.02254).

### Axle/Nut Options

Consult factory.

**IMPORTANT:** If caster stem is to be screwed into customer equipment, the customer must add a washer to the stem that will cover the incomplete threads and support the upper race. The stem shoulder must fit tightly against the customer equipment.

## Wheel Selection

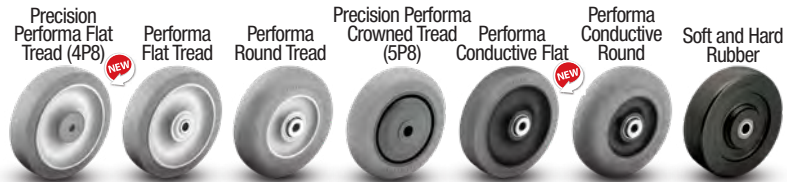

See the Performa Advantage on Page 55.



## Wheel Options

### Standard Thread Guards

Full thread guards are standard on Precision Polyurethane HI-TECH (9P8) and Performa Crowned Tread (5P8). Partial Thread Guards are standard on Precision Performa Rubber Flat Tread models (4P8).

### Optional Thread Guards

(See page 98) Available on many models. Specify **TG1** for metal or **TG2** for plastic; Example: 2.05254.441 TG2.

### Prevenz™ Antimicrobial for Medical and Food Service Industries.

This caster wheel additive inhibits the growth of harmful microbes, including bacteria, mold, and fungi. Available for Precision Performa Flat/Crowned and Precision Polyurethane HI-Tech. To order, add "PREV" to the caster number. Example: 2.05254.9P8 PREV.



## Mounting Options

### Standard Mounting (no code necessary):

1/2" diameter – 13UNC X 1 1/2" long, threaded 1 3/8".

- MTG10:** 1/2" 13UNC x 3/4" long threaded
- MTG11:** 1/2" 13UNC x 1" long threaded
- MTG12:** 1/2" 20UNF x 3/4" long threaded
- MTG13:** 5/8" 11UNC x 1 3/4" long threaded
- MTG14:** 5/8" 18UNF x 1 3/4" long threaded
- MTG15:** 3/4" 10UNC x 1 3/4" long threaded
- MTG16:** 5/8" 11UNC x 1 1/8" long threaded
- MTG18:** 5/8" 18 X 3.5" long threaded
- MTG19:** 1/2" 13UNC x 2.75" long threaded
- MTG24:** 3/4" 10UNC x 2.250" long threaded Zinc
- MTG25:** 5/8" 11UNC x 2 1/2" W/FLTS long threaded
- MTG26:** 3/4" 10UNC x 1" long threaded

- MTG28:** 1/2" 13UNC x 2.0" long threaded
- MTG36:** M14-2.00 x 1.50 long threaded
- MTG37:** 1/2" 13UNC X 1.75" long threaded
- MTG38:** M12 1.75 x 2" long threaded
- MTG39:** 7/16" 14UNC x 1.63" long threaded
- MTG48:** 1 1/4" UNC x 2" threaded to bottom
- MTG49:** 1 1/4" 12UNF x 2.56" hex top long threaded
- MTG50:** 1/2" 20UNF x 1 1/2" long threaded
- MTG90:** 3/8" 16UNF x 2" long threaded

To order optional mounting, add mounting code to Stem Caster Models number (Example: 2.02254.441 MTG10).

**3D CAD Models & Data Sheets**  
www.colsoncaster.com/casters

**Colson 2 Series Casters • Threaded Stem • Capacity to 350 lbs**

Wheel Dia.	Tread Width	Capacity Each (Pounds)	Wheel Descriptions	Standard Bearings	Swivel Caster Models	Optional Bearings	Load Height	Swivel Radius	Weight (Pounds)
2 1/2"	1 1/4"	125	Performa Flat Conductive	Ball	2.02254.445COND	–	3 3/4"	2 13/32"	1 3/4
		140	Performa Flat	Ball	2.02254.445	Delrin (441)	3 3/4"	2 13/32"	1 3/4
		200	Polyolefin	Ball	2.02254.55	Delrin (53)	3 3/4"	2 13/32"	1 3/4
		250	Polyurethane Hi-Tech Maroon	Ball	2.02254.95	Delrin (91)	3 3/4"	2 13/32"	1 1/2
		250	Polyurethane Hi-Tech Grey	Ball	2.02254.95G	Delrin (91G)	3 3/4"	2 13/32"	1 1/2
	300	Cast Iron	Plain	2.02254.12	–	–	3 3/4"	2 13/32"	2 1/8
	1 7/16"	300	Phenolic	Roller	2.02254.319	–	3 3/4"	2 13/32"	1 3/4
3"	1 1/4"	150	Soft Rubber	Plain	2.03354.RR2	–	4"	2 21/32"	2
		200	Polyolefin	Ball	2.03354.55	Delrin (52)	4"	2 21/32"	2
		200	Performa Flat	Ball	2.03354.445	Delrin (441)	4"	2 21/32"	2
		200	Precision Performa Flat	Precision Ball	2.03354.4P8	–	4"	2 21/32"	2
		200	Performa Crown	Precision Ball	2.03354.5P8	–	4"	2 21/32"	2
		200	Performa Flat Conductive	Ball	2.03354.445COND	–	4"	2 21/32"	2
		200	Polyolefin	Ball	2.03354.55	Delrin (52)	4"	2 21/32"	2
		300	Polyurethane Hi-Tech Maroon	Ball	2.03354.95	Delrin (91)	4"	2 21/32"	2
		300	Polyurethane Hi-Tech Grey	Ball	2.03354.95G	Delrin (91G)	4"	2 21/32"	2
		300	Precision Polyurethane Hi-Tech Grey	Precision Ball	2.03354.9P8	–	4"	2 21/32"	2
		300	K Solid Polyurethane	Plain	2.03354.KK2	–	4"	2 21/32"	2
		300	Cast Iron	Plain	2.03354.14	–	4"	2 21/32"	2 3/4
		350	Hard Rubber	Plain	2.03354.RN2	–	4"	2 21/32"	2
	1 15/32"	350	Phenolic	Roller	2.03354.309	–	4"	2 21/32"	2 3/4
3 1/2"	1 1/4"	150	Soft Rubber	Plain	2.03254.RR2	–	4 9/16"	2 29/32"	2 1/4
		250	Performa Flat	Ball	2.03254.445	Delrin (441)	4 9/16"	2 29/32"	2 1/8
		250	Performa Flat Conductive	Ball	2.03254.445COND	–	4 9/16"	2 29/32"	2 1/8
		250	Precision Performa Flat	Precision Ball	2.03254.4P8	–	4 9/16"	2 29/32"	2 1/8
		250	Performa Crown	Precision Ball	2.03254.5P8	–	4 9/16"	2 29/32"	2 1/8
	1 5/16"	250	Performa Round	Ball	2.03254.565	Delrin (561)	4 9/16"	2 29/32"	2 1/8
		250	Performa Round Conductive	Ball	2.03254.565COND	–	4 9/16"	2 29/32"	2 1/8
	1 1/4"	280	Polyolefin	Ball	2.03254.55	Delrin (53)	4 9/16"	2 29/32"	2 1/8
		300	Thermo	Plain	2.03254.52HT	–	4 9/16"	2 29/32"	3 1/8
		300	Cast Iron	Plain	2.03254.12	–	4 9/16"	2 29/32"	3
		350	Phenolic	Roller	2.03254.309	–	4 9/16"	2 29/32"	3
		350	Hard Rubber	Plain	2.03254.RN2	–	4 9/16"	2 29/32"	2 1/4
		350	Polyurethane Hi-Tech Maroon	Ball	2.03254.95	Delrin (91)	4 9/16"	2 29/32"	1 3/4
		350	Polyurethane Hi-Tech Grey	Ball	2.03254.95G	Delrin (91G)	4 9/16"	2 29/32"	1 3/4
	350	Precision Polyurethane Hi-Tech Grey	Precision Ball	2.03254.9P8	–	4 9/16"	2 29/32"	1 3/4	
4"	1 1/4"	150	Soft Rubber	Plain	2.04254.RR2	–	5"	3 29/32"	2 1/4
		300	Performa Flat	Ball	2.04254.445	Delrin (441)	5"	3 29/32"	2 1/4
		300	Performa Flat Conductive	Ball	2.04254.445COND	–	5"	3 29/32"	2 1/4
		300	Precision Performa Flat	Precision Ball	2.04254.4P8	–	5"	3 29/32"	2 1/4
		300	Performa Crown	Precision Ball	2.04254.5P8	–	5"	3 29/32"	2 1/4
		300	Thermo	Plain	2.04254.52HT	–	5"	3 29/32"	3 1/8
		300	Cast Iron	Plain	2.04254.12	–	5"	3 29/32"	3 3/8
		350	Polyolefin	Ball	2.04254.55	Delrin (53)	5"	3 29/32"	2 1/8
		350	Polyurethane Hi-Tech Maroon	Ball	2.04254.95	Delrin (91)	5"	3 29/32"	2 1/8
		350	Polyurethane Hi-Tech Grey	Ball	2.04254.95G	Delrin (91G)	5"	3 29/32"	2 1/8
		350	Precision Polyurethane Hi-Tech Grey	Precision Ball	2.04254.9P8	–	5"	3 29/32"	2 1/8
		350	K Solid Polyurethane	Plain	2.04354.KK2	–	5"	3 29/32"	2 1/8
		350	Hard Rubber	Plain	2.04254.RN2	–	5"	3 29/32"	2 1/4
	350	Phenolic	Roller	2.04254.309	–	5"	3 29/32"	3 3/8	
5"	1 1/4"	175	Soft Rubber	Plain	2.05254.RR2	–	6 1/16"	3 13/16"	3
		300	Cast Iron	Plain	2.05254.12	–	6 3/16"	3 13/16"	2 1/2
		325	Performa Flat	Ball	2.05254.445	Delrin (441)	6 1/16"	3 13/16"	3
		325	Performa Flat Conductive	Ball	2.05254.445COND	–	6 1/16"	3 13/16"	3
		325	Precision Performa Flat	Precision Ball	2.05254.445	–	6 1/16"	3 13/16"	3
	1 5/16"	325	Performa Crown	Precision Ball	2.05254.5P8	–	6 1/16"	3 13/16"	3
		325	Performa Round Conductive	Ball	2.05254.565COND	–	6 1/16"	3 13/16"	3
	1 1/4"	325	Performa Round	Ball	2.05254.565	Delrin (561)	6 1/16"	3 13/16"	3
		350	Hard Rubber	Plain	2.05254.RN2	–	6 1/16"	3 13/16"	3
		350	Polyolefin	Ball	2.05254.55	Delrin (53)	6 1/16"	3 13/16"	2 3/4
		350	Polyurethane Hi-Tech Maroon	Ball	2.05254.95	Delrin (91)	6 1/16"	3 13/16"	2 1/2
		350	Polyurethane Hi-Tech Grey	Ball	2.05254.95G	Delrin (91G)	6 1/16"	3 13/16"	2 1/2
		350	Precision Polyurethane Hi-Tech Grey	Precision Ball	2.05254.9P8	–	6 1/16"	3 13/16"	2 1/2
		350	K Solid Polyurethane	Plain	2.05354.KK2	–	6 1/16"	3 13/16"	2 1/2
350	Thermo	Plain	2.05254.52HT	–	6 1/16"	3 13/16"	3 3/4		
350	Phenolic	Roller	2.05254.309	–	6 1/16"	3 13/16"	3 3/4		
6"	1 1/4"	350	Performa Flat	Ball	2.06254.445	Delrin (441)	7 1/8"	4 5/16"	3 1/2
		350	Performa Flat Conductive	Ball	2.06254.445COND	–	7 1/8"	4 5/16"	3 1/2
		350	Polyurethane Hi-Tech Maroon	Ball	2.06254.95	Delrin (91)	7 1/8"	4 5/16"	3
		350	Polyurethane Hi-Tech Grey	Ball	2.06254.95G	Delrin (91G)	7 1/8"	4 5/16"	3
		350	Polyolefin	Ball	2.06254.55	Delrin (53)	7 1/8"	4 5/16"	3

**2 Series**

# 2 Series

Capacity up to **350 lbs each**

GRIP RING STEM



Consult factory for RoHS requirements on a part specific basis.



Consult the NSF listing page on a part specific basis for NSF requirements.



## Features

- Zinc plated finish is attractive and durable
- Full double ball hardened raceways for better performance and greater durability
- 3/8" hollow axle with lock nut
- Grease holes on wheel bearing for greater convenience
- "Colson 45" multi-temp grease lubricates in extreme hot and cold temperatures

## Standard Mounting

- **Stem Size:** 2 3/16" long with 5/8" diameter
- Stem features spring grip at top to hold caster securely in tubing
- Assures tight fit and easy swivel action

## Standard Dimensions

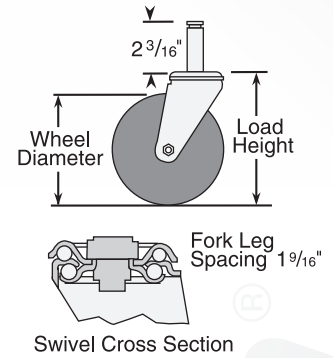

## Caster Brake



**Top Lock**  
(See page 86) Available on all swivel models with solid axle only. Field installable (Specify **BRK1**; Example: 2.05251.91 BRK1).



**Posi Lock**  
(See page 87) Available on all swivels. Field installable (Specify **BRK8**; Example: 2.05251.9P8 BRK8).



**Total Lock**  
(See page 86) Locks wheel and swivel simultaneously. Fits 3 1/2", 4" and 5" swivel models. Field installable.

**Note:** When mounted in tubing, brake will function as wheel brake only. (Specify **BRK5**; Example: 2.05251.445 COND BRK5).

## Fork Option

**NSF Listed For Food Service Industry**  
Consult factory for details.

**Swivel Dust Cap**  
(See page 90) (Specify **DC1**; Example: 2.05251.441 DC1).

**Forks Only**  
To order caster forks only use 1st 6 digits of model numbers (Example: 2.02251).

**Axle/Nut Options**  
Consult factory.

## Wheel Selection

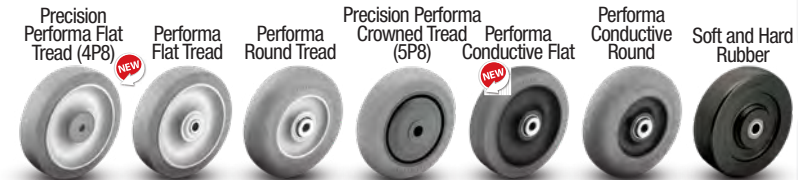

See the Performa Advantage on Page 55.



## Wheel Options

**Standard Thread Guards**  
Full thread guards are standard on Precision Polyurethane HI-TECH (9P8) and Performa Crowned Tread (5P8). Partial Thread Guards are standard on Precision Performa Rubber Flat Tread models (4P8).

**Optional Thread Guards** (See page 98) Available on many models. Specify **TG1** for metal or **TG2** for plastic; Example: 2.05251.441 TG2.

**Prevenz™ Antimicrobial for Medical and Food Service Industries.** This caster wheel additive inhibits the growth of harmful microbes, including bacteria, mold, and fungi. Available for Precision Performa Flat/Crowned and Precision Polyurethane Hi-Tech. To order, add "**PREV**" to the caster number. Example: 2.05251.9P8 **PREV**.



## Mounting Options

**Standard Mounting (no code necessary):**  
2 3/16" long with 5/8" dia.

- MTG5:** 2 3/16" x 3/4" (.750" - 1 Grip Ring)
- MTG6:** 2 3/16" x 13/16" (.812" - 1 Grip Ring)
- MTG7:** 2 3/16" x 27/32" (.845" - 1 Grip Ring)
- MTG8:** 2 3/16" x 7/8" (.865" - 1 Grip Ring)

- MTG9:** 2 3/16" x 1" (1.00" - 1 Grip Ring)
- MTG61:** 2 3/16" x 7/8" (.865" - 2 Groove)
- MTG62:** 2 3/16" x 17/32" (.845" - 2 Groove)
- MTG69:** 2 3/16" x 27/32" (.865" SQ Stem)

To order optional mounting, add mounting code to Stem Caster Models number (Example: 2.02251.441 MTG2).

**Colson 2 Series Casters • Grip Ring Stem • Capacity to 350 lbs**

Wheel Dia.	Tread Width	Capacity Each (Pounds)	Wheel Descriptions	Standard Bearings	Swivel Caster Models	Optional Bearings	Load Height	Swivel Radius	Weight (Pounds)
2 1/2"	1 1/4"	125	Performa Flat Conductive	Ball	2.02251.445COND	-	3 3/4"	2 13/32"	1 3/4
		140	Performa Flat	Ball	2.02251.445	Delrin (441)	3 3/4"	2 13/32"	1 3/4
		200	Polyolefin	Ball	2.02251.55	Delrin (53)	3 3/4"	2 13/32"	1 3/4
		250	Polyurethane Hi-Tech Maroon	Ball	2.02251.95	Delrin (91)	3 3/4"	2 13/32"	1 1/2
		250	Polyurethane Hi-Tech Grey	Ball	2.02251.95G	Delrin (91G)	3 3/4"	2 13/32"	1 1/2
		300	Cast Iron	Plain	2.02251.12	-	3 3/4"	2 13/32"	2 1/8
	1 7/16"	300	Phenolic	Roller	2.02251.319	-	3 3/4"	2 13/32"	1 3/4
3"	1 1/4"	150	Soft Rubber	Plain	2.03351.RR2	-	4"	2 21/32"	2
		200	Polyolefin	Ball	2.03351.55	Delrin (52)	4"	2 21/32"	2
		200	Performa Flat	Ball	2.03351.445	Delrin (441)	4"	2 21/32"	2
		200	Precision Performa Flat	Precision Ball	2.03351.4P8	-	4"	2 21/32"	2
		200	Performa Crown	Precision Ball	2.03351.5P8	-	4"	2 21/32"	2
		200	Performa Flat Conductive	Ball	2.03351.445COND	-	4"	2 21/32"	2
		200	Polyolefin	Ball	2.03351.55	Delrin (52)	4"	2 21/32"	2
		300	Polyurethane Hi-Tech Maroon	Ball	2.03351.95	Delrin (91)	4"	2 21/32"	2
		300	Polyurethane Hi-Tech Grey	Ball	2.03351.95G	Delrin (91G)	4"	2 21/32"	2
		300	Precision Polyurethane Hi-Tech Grey	Precision Ball	2.03351.9P8	-	4"	2 21/32"	2
		300	K Solid Polyurethane	Plain	2.03351.KK2	-	4"	2 21/32"	2
		300	Cast Iron	Plain	2.03351.14	-	4"	2 21/32"	2 3/4
		350	Hard Rubber	Plain	2.03351.RN2	-	4"	2 21/32"	2
	1 15/32"	350	Phenolic	Roller	2.03351.309	-	4"	2 21/32"	2 3/4
3 1/2"	1 1/4"	150	Soft Rubber	Plain	2.03251.RR2	-	4 9/16"	2 29/32"	2 1/4
		250	Performa Flat	Ball	2.03251.445	Delrin (441)	4 9/16"	2 29/32"	2 1/8
		250	Performa Flat Conductive	Ball	2.03251.445COND	-	4 9/16"	2 29/32"	2 1/8
		250	Precision Performa Flat	Precision Ball	2.03251.4P8	-	4 9/16"	2 29/32"	2 1/8
		250	Performa Crown	Precision Ball	2.03251.5P8	-	4 9/16"	2 29/32"	2 1/8
		250	Performa Round	Ball	2.03251.565	Delrin (561)	4 9/16"	2 29/32"	2 1/8
	1 5/16"	250	Performa Round Conductive	Ball	2.03251.565COND	-	4 9/16"	2 29/32"	2 1/8
		280	Polyolefin	Ball	2.03251.55	Delrin (53)	4 9/16"	2 29/32"	2 1/8
		300	Thermo	Plain	2.03251.52HT	-	4 9/16"	2 29/32"	3 1/8
		300	Cast Iron	Plain	2.03251.12	-	4 9/16"	2 29/32"	3
		350	Phenolic	Roller	2.03251.309	-	4 9/16"	2 29/32"	3
		350	Hard Rubber	Plain	2.03251.RN2	-	4 9/16"	2 29/32"	2 1/4
		350	Polyurethane Hi-Tech Maroon	Ball	2.03251.95	Delrin (91)	4 9/16"	2 29/32"	1 3/4
		350	Polyurethane Hi-Tech Grey	Ball	2.03251.95G	Delrin (91G)	4 9/16"	2 29/32"	1 3/4
		350	Precision Polyurethane Hi-Tech Grey	Precision Ball	2.03251.9P8	-	4 9/16"	2 29/32"	1 3/4
4"	1 1/4"	150	Soft Rubber	Plain	2.04251.RR2	-	5"	3 29/32"	2 1/4
		300	Performa Flat	Ball	2.04251.445	Delrin (441)	5"	3 29/32"	2 1/4
		300	Performa Flat Conductive	Ball	2.04251.445COND	-	5"	3 29/32"	2 1/4
		300	Precision Performa Flat	Precision Ball	2.04251.4P8	-	5"	3 29/32"	2 1/4
		300	Performa Crown	Precision Ball	2.04251.5P8	-	5"	3 29/32"	2 1/4
		300	Thermo	Plain	2.04251.52HT	-	5"	3 29/32"	3 1/8
		300	Cast Iron	Plain	2.04251.12	-	5"	3 29/32"	3 3/8
		350	Polyolefin	Ball	2.04251.55	Delrin (53)	5"	3 29/32"	2 1/8
		350	Polyurethane Hi-Tech Maroon	Ball	2.04251.95	Delrin (91)	5"	3 29/32"	2 1/8
		350	Polyurethane Hi-Tech Grey	Ball	2.04251.95G	Delrin (91G)	5"	3 29/32"	2 1/8
		350	Precision Polyurethane Hi-Tech Grey	Precision Ball	2.04251.9P8	-	5"	3 29/32"	2 1/8
		350	K Solid Polyurethane	Plain	2.04351.KK2	-	5"	3 29/32"	2 1/8
		350	Hard Rubber	Plain	2.04251.RN2	-	5"	3 29/32"	2 1/4
	350	Phenolic	Roller	2.04251.309	-	5"	3 29/32"	3 3/8	
	5"	1 1/4"	175	Soft Rubber	Plain	2.05251.RR2	-	6 1/16"	3 13/16"
300			Cast Iron	Plain	2.05251.12	-	6 3/16"	3 13/16"	2 1/2
325			Performa Flat	Ball	2.05251.445	Delrin (441)	6 1/16"	3 13/16"	3
325			Performa Flat Conductive	Ball	2.05251.445COND	-	6 1/16"	3 13/16"	3
325			Precision Performa Flat	Precision Ball	2.05251.445	-	6 1/16"	3 13/16"	3
325			Performa Crown	Precision Ball	2.05251.5P8	-	6 1/16"	3 13/16"	3
1 5/16"		325	Performa Round Conductive	Ball	2.05251.565COND	-	6 1/16"	3 13/16"	3
		325	Performa Round	Ball	2.05251.565	Delrin (561)	6 1/16"	3 13/16"	3
		350	Hard Rubber	Plain	2.05251.RN2	-	6 1/16"	3 13/16"	3
		350	Polyolefin	Ball	2.05251.55	Delrin (53)	6 1/16"	3 13/16"	2 3/4
		350	Polyurethane Hi-Tech Maroon	Ball	2.05251.95	Delrin (91)	6 1/16"	3 13/16"	2 1/2
		350	Polyurethane Hi-Tech Grey	Ball	2.05251.95G	Delrin (91G)	6 1/16"	3 13/16"	2 1/2
		350	Precision Polyurethane Hi-Tech Grey	Precision Ball	2.05251.9P8	-	6 1/16"	3 13/16"	2 1/2
		350	K Solid Polyurethane	Plain	2.05351.KK2	-	6 1/16"	3 13/16"	2 1/2
		350	Thermo	Plain	2.05251.52HT	-	6 1/16"	3 13/16"	3 3/4
350	Phenolic	Roller	2.05251.309	-	6 1/16"	3 13/16"	3 3/4		
6"	1 1/4"	350	Performa Flat	Ball	2.06251.445	Delrin (441)	7 1/8"	4 5/16"	3 1/2
		350	Performa Flat Conductive	Ball	2.06251.445COND	-	7 1/8"	4 5/16"	3 1/2
		350	Polyurethane Hi-Tech Maroon	Ball	2.06251.95	Delrin (91)	7 1/8"	4 5/16"	3
		350	Polyurethane Hi-Tech Grey	Ball	2.06251.95G	Delrin (91G)	7 1/8"	4 5/16"	3
		350	Polyolefin	Ball	2.06251.55	Delrin (53)	7 1/8"	4 5/16"	3

**2 Series**



# 2 Series

EXPANDING ADAPTER STEM

Capacity up to **350 lbs each**



Consult factory for RoHS requirements on a part specific basis.

Consult the NSF listing page on a part specific basis for NSF requirements.



## Standard Dimensions

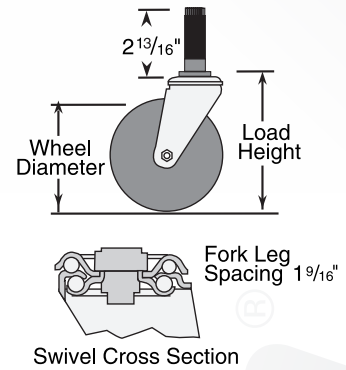

## Features

- Zinc plated finish is attractive and durable
- Full double ball hardened raceways for better performance and greater durability
- 3/8" hollow axle with lock nut
- Grease holes on wheel bearing for greater convenience
- "Colson 45" multi-temp grease lubricates in extreme hot and cold temperatures

## Standard Mounting

- Turning of hex nut beneath lower raceway expands rubber adapter inside of round or square tubing for a tight, permanent fit
- To order, select caster model number and specify stem adapter size by code number from mounting options chart below

## Caster Brake



**Top Lock**  
(See page 86) Available on all swivel models with solid axle only. Field installable (Specify **BRK1**; Example: 2.05267.91 MTG40 BRK1).



**Posi Lock**  
(See page 87) Available on all swivels. Field installable (Specify **BRK8**; Example: 2.05267.RR2 BRK8).



**Total Lock**  
(See page 86) Locks wheel and swivel simultaneously. Fits 3 1/2", 4" and 5" swivel models. Field installable (Specify **BRK5**; Example: 2.05267.53 MTG40 BRK5).

## Fork Option

**NSF Listed For Food Service Industry**  
Consult factory for details.

**Swivel Dust Cap**  
(See page 90) (Specify **DC1**; Example: 2.05267.441 MTG40 DC1).

**Forks Only**  
To order caster forks only use 1st 6 digits of model numbers (Example: 2.02267).

**Axle/Nut Options**  
Consult factory.

## Wheel Selection



See the Performa Advantage on Page 55.

## Mounting Options

(See page 97)

Inside Diameter of Tube	Mounting Code Numbers	
	Round Tubing	Square Tubing
3/4" - 13/16"	MTG40	-
7/8" - 15/16"	MTG41	MTG51
1" - 1 1/16"	MTG42	MTG52
1 1/8" - 1 3/16"	MTG43	MTG53
1 1/4" - 1 5/16"	MTG44	MTG54
1 3/8" - 1 7/16"	MTG45	MTG55
1 1/2" - 1 9/16"	MTG46	-
1 5/8" - 1 11/16"	MTG47	-

Stems are 2 11/16" long. Stem size less adapter: 1/2" - 13UNC x 2 13/16"

## Wheel Options

**Standard Thread Guards**  
Full thread guards are standard on Precision Polyurethane HI-TECH (9P8) and Performa Crowned Tread (5P8). Partial Thread Guards are standard on Precision Performa Rubber Flat Tread models (4P8).

**Optional Thread Guards**  
(See page 98) Available on many models. Specify **TG1** for metal or **TG2** for plastic; Example: 2.05267.441 MTG40 TG2.

**Prevenz™ Antimicrobial for Medical and Food Service Industries.** This caster wheel additive inhibits the growth of harmful microbes, including bacteria, mold, and fungi. Available for Precision Performa Flat/Crowned and Precision Polyurethane Hi-Tech. To order, add "PREV" to the caster number. Example: 2.05267.9P8 PREV.



To order you must add the mounting code to the Stem Caster Model number (Example: 2.02267.441 MTG40).

3D CAD Models & Data Sheets  
www.colsoncaster.com/casters

**Colson 2 Series Casters • Expanding Adapter Stem • Capacity to 350 lbs**

Wheel Dia.	Tread Width	Capacity Each (Pounds)	Wheel Descriptions	Standard Bearings	Swivel Caster Models	Optional Bearings	Load Height	Swivel Radius	Weight (Pounds)	
2 1/2"	1 1/4"	140	Performa Flat	Ball	2.02267.445	Delrin (441)	4"	2 13/32"	1 5/8	
		200	Polyolefin	Ball	2.02267.55	Delrin (53)	4"	2 13/32"	1 5/8	
		250	Polyurethane Hi-Tech Maroon	Ball	2.02267.95	Delrin (91)	4"	2 13/32"	1 5/8	
		250	Polyurethane Hi-Tech Grey	Ball	2.02267.95G	Delrin (91G)	4"	2 13/32"	1 5/8	
	1 7/16"	300	Cast Iron	Plain	2.02267.12	—	4"	2 13/32"	2	
		300	Phenolic	Roller	2.02267.319	—	4"	2 13/32"	1 5/8	
3"	1 1/4"	150	Soft Rubber	Plain	2.03367.RR2	—	4 1/4"	2 21/32"	2	
		200	Polyolefin	Ball	2.03367.55	Delrin (52)	4 1/4"	2 21/32"	2	
		200	Performa Flat	Ball	2.03367.445	Delrin (441)	4 1/4"	2 21/32"	2	
		200	Precision Performa Flat	Precision Ball	2.03367.4P8	—	4 1/4"	2 21/32"	2	
		200	Performa Crown	Precision Ball	2.03367.5P8	—	4 1/4"	2 21/32"	2	
		200	Polyolefin	Ball	2.03367.55	Delrin (52)	4 1/4"	2 21/32"	2	
		300	Polyurethane Hi-Tech Maroon	Ball	2.03367.95	Delrin (91)	4 1/4"	2 21/32"	2	
		300	Polyurethane Hi-Tech Grey	Ball	2.03367.95G	Delrin (91G)	4 1/4"	2 21/32"	2	
		300	Precision Polyurethane Hi-Tech Grey	Precision Ball	2.03367.9P8	—	4 1/4"	2 21/32"	2	
		300	K Solid Polyurethane	Plain	2.03367.KK2	—	4 1/4"	2 21/32"	2	
	1 15/32"	300	Cast Iron	Plain	2.03367.14	—	4 1/4"	2 21/32"	2 3/4	
		350	Hard Rubber	Plain	2.03367.RN2	—	4 1/4"	2 21/32"	2	
	3 1/2"	1 1/4"	150	Soft Rubber	Plain	2.03267.RR2	—	4 9/16"	2 29/32"	2 1/4
			250	Performa Flat	Ball	2.03267.445	Delrin (441)	4 9/16"	2 29/32"	2 1/8
250			Precision Performa Flat	Precision Ball	2.03267.4P8	—	4 9/16"	2 29/32"	2 1/8	
250			Performa Crown	Precision Ball	2.03267.5P8	—	4 9/16"	2 29/32"	2 1/8	
1 5/16"		250	Performa Round	Ball	2.03267.565	Delrin (561)	4 9/16"	2 29/32"	2 1/8	
		280	Polyolefin	Ball	2.03267.55	Delrin (53)	4 9/16"	2 29/32"	2 1/8	
1 1/4"		300	Cast Iron	Plain	2.03267.12	—	4 9/16"	2 29/32"	3	
		350	Phenolic	Roller	2.03267.309	—	4 9/16"	2 29/32"	3	
		350	Hard Rubber	Plain	2.03267.RN2	—	4 9/16"	2 29/32"	2 1/4	
		350	Polyurethane Hi-Tech Maroon	Ball	2.03267.95	Delrin (91)	4 9/16"	2 29/32"	1 3/4	
		350	Polyurethane Hi-Tech Grey	Ball	2.03267.95G	Delrin (91G)	4 9/16"	2 29/32"	1 3/4	
		350	Precision Polyurethane Hi-Tech Grey	Precision Ball	2.03267.9P8	—	4 9/16"	2 29/32"	1 3/4	
4"		1 1/4"	150	Soft Rubber	Plain	2.04267.RR2	—	5 1/4"	3 29/32"	2 1/4
			300	Performa Flat	Ball	2.04267.445	Delrin (441)	5 1/4"	3 29/32"	2 1/4
	300		Precision Performa Flat	Precision Ball	2.04267.4P8	—	5 1/4"	3 29/32"	2 1/4	
	300		Performa Crown	Precision Ball	2.04267.5P8	—	5 1/4"	3 29/32"	2 1/4	
	300		Cast Iron	Plain	2.04267.12	—	5 1/4"	3 29/32"	3 3/8	
	350		Polyolefin	Ball	2.04267.55	Delrin (53)	5 1/4"	3 29/32"	2 1/8	
	350		Polyurethane Hi-Tech Maroon	Ball	2.04267.95	Delrin (91)	5 1/4"	3 29/32"	2 1/8	
	350		Polyurethane Hi-Tech Grey	Ball	2.04267.95G	Delrin (91G)	5 1/4"	3 29/32"	2 1/8	
	1 1/4"	350	Precision Polyurethane Hi-Tech Grey	Precision Ball	2.04267.9P8	—	5 1/4"	3 29/32"	2 1/8	
		350	K Solid Polyurethane	Plain	2.04367.KK2	—	4 1/4"	2 21/32"	2	
		350	Hard Rubber	Plain	2.04267.RN2	—	5 1/4"	3 29/32"	2 1/4	
		350	Phenolic	Roller	2.04267.309	—	5 1/4"	3 29/32"	3 3/8	
5"	1 1/4"	175	Soft Rubber	Plain	2.05267.RR2	—	6 5/16"	3 13/16"	3	
		300	Cast Iron	Plain	2.05267.12	—	6 3/16"	3 13/16"	2 1/2	
		325	Performa Flat	Ball	2.05267.445	Delrin (441)	6 5/16"	3 13/16"	3 1/2	
		325	Precision Performa Flat	Precision Ball	2.05267.445	—	6 5/16"	3 13/16"	3 1/2	
		325	Performa Crown	Precision Ball	2.05267.5P8	—	6 5/16"	3 13/16"	3 1/2	
	1 5/16"	325	Performa Round	Ball	2.05267.565	Delrin (561)	6 5/16"	3 13/16"	3 1/2	
		350	Hard Rubber	Plain	2.05267.RN2	—	6 5/16"	3 13/16"	3	
	1 1/4"	350	Polyolefin	Ball	2.05267.55	Delrin (53)	6 5/16"	3 13/16"	2 1/2	
		350	Polyurethane Hi-Tech Maroon	Ball	2.05267.95	Delrin (91)	6 5/16"	3 13/16"	2 1/2	
		350	Polyurethane Hi-Tech Grey	Ball	2.05267.95G	Delrin (91G)	6 5/16"	3 13/16"	2 1/2	
		350	Precision Polyurethane Hi-Tech Grey	Precision Ball	2.05267.9P8	—	6 5/16"	3 13/16"	2 1/2	
		350	K Solid Polyurethane	Plain	2.05367.KK2	—	4 1/4"	2 21/32"	2	
		350	Phenolic	Roller	2.05267.309	—	6 5/16"	3 13/16"	3 3/4	
		6"	1 1/4"	350	Performa Flat	Ball	2.06267.445	Delrin (441)	7 3/8"	4 5/16"
350	Polyurethane Hi-Tech Maroon			Ball	2.06267.95	Delrin (91)	7 3/8"	4 5/16"	2 3/4	
350	Polyurethane Hi-Tech Grey			Ball	2.06267.95G	Delrin (91G)	7 3/8"	4 5/16"	2 3/4	
350	Polyolefin			Ball	2.06267.55	Delrin (53)	7 3/8"	4 5/16"	2 3/4	

\*To order you must include mounting code in the Mounting Option chart on previous page. (Example: 2.02267.441 MTG40).

**2 Series**

# 2 Series

Capacity up to **350 lbs each**

MODULAR STEM



Consult factory for RoHS requirements on a part specific basis.



Consult the NSF listing page on a part specific basis for NSF requirements.



## Standard Dimensions

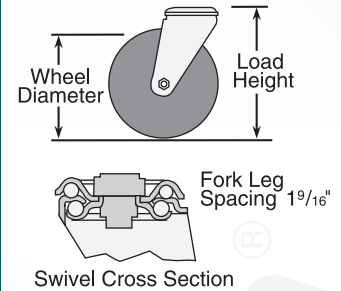

## Features

- Zinc plated finish is attractive and durable
- Full double ball hardened raceways for better performance and greater durability
- 3/8" hollow axle with lock nut
- Grease holes on wheel bearing for greater convenience
- "Colson 45" multi-temp grease lubricates in extreme hot and cold temperatures

## Standard Mounting

- Colson modular stem casters feature a 1/2" hollow rivet which will accept a wide variety of mounting stems (even a standard 1/2" bolt will work)
- You can supply the mounting fasteners or stems – we supply the casters

## Caster Brake



**Top Lock**  
(See page 86) Available on all swivel models with solid axle only. Field installable (Specify **BRK1**; Example: 2.05250.91 BRK1).



**Posi Lock**  
(See page 87) Available on all swivels. Field installable (Specify **BRK8**; Example: 2.05250.319 BRK8).



**Total Lock**  
(See page 86) Locks wheel and swivel simultaneously. Fits 3 1/2", 4" and 5" swivel models. Field installable (Specify **BRK5**; Example: 2.05250.565 COND BRK5).

## Fork Option

**NSF Listed For Food Service Industry**  
Consult factory for details.

**Swivel Dust Cap**  
(See page 90) (Specify **DC1**; Example: 2.05250.441 DC1).

**Forks Only**  
To order caster forks only use 1st 6 digits of model numbers (Example: 2.02250).

**Axle/Nut Options**  
Consult factory.

## Wheel Selection



See the Performa Advantage on Page 55.

## Wheel Options

**Standard Thread Guards**  
Full thread guards are standard on Precision Polyurethane HI-TECH (9P8) and Performa Crowned Tread (5P8). Partial Thread Guards are standard on Precision Performa Rubber Flat Tread models (4P8).

**Optional Thread Guards**  
(See page 98) Available on many models. Specify **TG1** for metal or **TG2** for plastic; Example: 2.05250.441 TG2.

**Prevenz™ Antimicrobial for Medical and Food Service Industries.** This caster wheel additive inhibits the growth of harmful microbes, including bacteria, mold, and fungi. Available for Precision Performa Flat/Crowned and Precision Polyurethane Hi-Tech. To order, add "PREV" to the caster number. Example: 2.05250.9P8 PREV.



**Colson 2 Series Casters • Modular Stem • Capacity to 350 lbs**

Wheel Dia.	Tread Width	Capacity Each (Pounds)	Wheel Descriptions	Standard Bearings	Swivel Caster Models	Optional Bearings	Load Height	Swivel Radius	Weight (Pounds)	
2 1/2"	1 1/4"	125	Performa Flat Conductive	Ball	2.02250.445COND	-	3 3/4"	2 13/32"	1 1/2	
		140	Performa Flat	Ball	2.02250.445	Delrin (441)	3 3/4"	2 13/32"	1 1/2	
		200	Polyolefin	Ball	2.02250.55	Delrin (53)	3 3/4"	2 13/32"	1 1/2	
		250	Polyurethane Hi-Tech Maroon	Ball	2.02250.95	Delrin (91)	3 3/4"	2 13/32"	1 1/2	
		250	Polyurethane Hi-Tech Grey	Ball	2.02250.95G	Delrin (91G)	3 3/4"	2 13/32"	1 1/2	
	300	Cast Iron	Plain	2.02250.12	-	-	3 3/4"	2 13/32"	2 1/8	
	1 7/16"	300	Phenolic	Roller	2.02250.319	-	3 3/4"	2 13/32"	1 3/4	
3"	1 1/4"	150	Soft Rubber	Plain	2.03350.RR2	-	4"	2 21/32"	2	
		200	Polyolefin	Ball	2.03350.55	Delrin (52)	4"	2 21/32"	2	
		200	Performa Flat	Ball	2.03350.445	Delrin (441)	4"	2 21/32"	2	
		200	Precision Performa Flat	Precision Ball	2.03350.4P8	-	4"	2 21/32"	2	
		200	Performa Crown	Precision Ball	2.03350.5P8	-	4"	2 21/32"	2	
		200	Performa Flat Conductive	Ball	2.03350.445COND	-	4"	2 21/32"	2	
		200	Polyolefin	Ball	2.03350.55	Delrin (52)	4"	2 21/32"	2	
		300	Polyurethane Hi-Tech Maroon	Ball	2.03350.95	Delrin (91)	4"	2 21/32"	2	
		300	Polyurethane Hi-Tech Grey	Ball	2.03350.95G	Delrin (91G)	4"	2 21/32"	2	
		300	Precision Polyurethane Hi-Tech Grey	Precision Ball	2.03350.9P8	-	4"	2 21/32"	2	
		300	K Solid Polyurethane	Plain	2.03350.KK2	-	4"	2 21/32"	2	
		300	Cast Iron	Plain	2.03350.14	-	4"	2 21/32"	2 3/4	
	350	Hard Rubber	Plain	2.03350.RN2	-	4"	2 21/32"	2		
	1 15/32"	350	Phenolic	Roller	2.03350.309	-	4"	2 21/32"	2 3/4	
3 1/2"	1 1/4"	150	Soft Rubber	Plain	2.03250.RR2	-	4 9/16"	2 29/32"	2 1/4	
		250	Performa Flat	Ball	2.03250.445	Delrin (441)	4 9/16"	2 29/32"	2 1/8	
		250	Performa Flat Conductive	Ball	2.03250.445COND	-	4 9/16"	2 29/32"	2 1/8	
		250	Precision Performa Flat	Precision Ball	2.03250.4P8	-	4 9/16"	2 29/32"	2 1/8	
		250	Performa Crown	Precision Ball	2.03250.5P8	-	4 9/16"	2 29/32"	2 1/8	
		250	Performa Round	Ball	2.03250.565	Delrin (561)	4 9/16"	2 29/32"	2 1/8	
	1 5/16"	250	Performa Round Conductive	Ball	2.03250.565COND	-	4 9/16"	2 29/32"	2 1/8	
		280	Polyolefin	Ball	2.03250.55	Delrin (53)	4 9/16"	2 29/32"	2 1/8	
		300	Thermo	Plain	2.03250.52HT	-	4 9/16"	2 29/32"	3 1/8	
		300	Cast Iron	Plain	2.03250.12	-	4 9/16"	2 29/32"	3	
		350	Phenolic	Roller	2.03250.309	-	4 9/16"	2 29/32"	3	
		350	Hard Rubber	Plain	2.03250.RN2	-	4 9/16"	2 29/32"	2 1/4	
		350	Polyurethane Hi-Tech Maroon	Ball	2.03250.95	Delrin (91)	4 9/16"	2 29/32"	1 3/4	
		350	Polyurethane Hi-Tech Grey	Ball	2.03250.95G	Delrin (91G)	4 9/16"	2 29/32"	1 3/4	
	350	Precision Polyurethane Hi-Tech Grey	Precision Ball	2.03250.9P8	-	4 9/16"	2 29/32"	1 3/4		
4"	1 1/4"	150	Soft Rubber	Plain	2.04250.RR2	-	5"	3 29/32"	2 1/4	
		300	Performa Flat	Ball	2.04250.445	Delrin (441)	5"	3 29/32"	2 1/4	
		300	Performa Flat Conductive	Ball	2.04250.445COND	-	5"	3 29/32"	2 1/4	
		300	Precision Performa Flat	Precision Ball	2.04250.4P8	-	5"	3 29/32"	2 1/4	
		300	Performa Crown	Precision Ball	2.04250.5P8	-	5"	3 29/32"	2 1/4	
		300	Thermo	Plain	2.04250.52HT	-	5"	3 29/32"	3 1/8	
		300	Cast Iron	Plain	2.04250.12	-	5"	3 29/32"	3 3/8	
		350	Polyolefin	Ball	2.04250.55	Delrin (53)	5"	3 29/32"	2 1/8	
		350	Polyurethane Hi-Tech Maroon	Ball	2.04250.95	Delrin (91)	5"	3 29/32"	2 1/8	
		350	Polyurethane Hi-Tech Grey	Ball	2.04250.95G	Delrin (91G)	5"	3 29/32"	2 1/8	
		350	Precision Polyurethane Hi-Tech Grey	Precision Ball	2.04250.9P8	-	5"	3 29/32"	2 1/8	
		350	K Solid Polyurethane	Plain	2.04350.KK2	-	4"	2 21/32"	2	
		350	Hard Rubber	Plain	2.04250.RN2	-	5"	3 29/32"	2 1/4	
		350	Phenolic	Roller	2.04250.309	-	5"	3 29/32"	3 3/8	
5"	1 1/4"	175	Soft Rubber	Plain	2.05250.RR2	-	6 1/16"	3 13/16"	3	
		300	Cast Iron	Plain	2.05250.12	-	6 3/16"	3 13/16"	2 1/2	
		325	Performa Flat	Ball	2.05250.445	Delrin (441)	6 1/16"	3 13/16"	3	
		325	Performa Flat Conductive	Ball	2.05250.445COND	-	6 1/16"	3 13/16"	3	
		325	Precision Performa Flat	Precision Ball	2.05250.445	-	6 1/16"	3 13/16"	3	
		325	Performa Crown	Precision Ball	2.05250.5P8	-	6 1/16"	3 13/16"	3	
	1 5/16"	325	Performa Round Conductive	Ball	2.05250.565COND	-	6 1/16"	3 13/16"	3	
		325	Performa Round	Ball	2.05250.565	Delrin (561)	6 1/16"	3 13/16"	3	
		350	Hard Rubber	Plain	2.05250.RN2	-	6 1/16"	3 13/16"	3	
		350	Polyolefin	Ball	2.05250.55	Delrin (53)	6 1/16"	3 13/16"	2 3/4	
		350	Polyurethane Hi-Tech Maroon	Ball	2.05250.95	Delrin (91)	6 1/16"	3 13/16"	2 1/2	
		350	Polyurethane Hi-Tech Grey	Ball	2.05250.95G	Delrin (91G)	6 1/16"	3 13/16"	2 1/2	
		350	Precision Polyurethane Hi-Tech Grey	Precision Ball	2.05250.9P8	-	6 1/16"	3 13/16"	2 1/2	
		350	K Solid Polyurethane	Plain	2.05350.KK2	-	4"	2 21/32"	2	
1 1/4"	350	Thermo	Plain	2.05250.52HT	-	6 1/16"	3 13/16"	3 3/4		
	350	Phenolic	Roller	2.05250.309	-	6 1/16"	3 13/16"	3 3/4		
	6"	1 1/4"	350	Performa Flat	Ball	2.06250.445	Delrin (441)	7 1/8"	4 5/16"	3 1/2
			350	Performa Flat Conductive	Ball	2.06250.445COND	-	7 1/8"	4 5/16"	3 1/2
			350	Polyurethane Hi-Tech Maroon	Ball	2.06250.95	Delrin (91)	7 1/8"	4 5/16"	3
			350	Polyurethane Hi-Tech Grey	Ball	2.06250.95G	Delrin (91G)	7 1/8"	4 5/16"	3
350			Polyolefin	Ball	2.06250.55	Delrin (53)	7 1/8"	4 5/16"	3	

**2 Series**

# 2 Series

Square Stem Swivel & Rigid  
Capacity up to **350 lbs each**



Consult factory for RoHS requirements on a part specific basis.

Consult the NSF listing page on a part specific basis for NSF requirements.



## Standard Dimensions

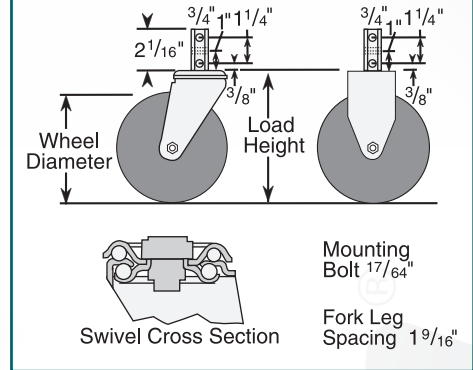

## Features

- Zinc plated finish is attractive and durable
- Full double ball hardened raceways for better performance and greater durability
- 3/8" hollow axle with lock nut
- Grease holes on wheel bearing for greater convenience
- "Colson 45" multi-temp grease lubricates in extreme hot and cold temperatures

## Standard Mounting

- **Stem Size:** 2 1/16" long x 3/4" square with 3 mounting holes 17/64" diameter
- Designed for easy installation on the inside of angle iron legs or against flat surfaces
- Stems may be bolted or riveted against any flat vertical surface

## Caster Brake



**Top Lock**  
(See page 86) Available on all swivel models with solid axle only. Field installable (Specify **BRK1**; Example: 2.05270.91 BRK1).



**Posi Lock**  
(See page 87) Available on all swivels. Field installable (Specify **BRK8**; Example: 2.05270.4P5 BRK8).



**Total Lock**  
(See page 86) Locks wheel and swivel simultaneously. Fits 3 1/2", 4" and 5" swivel models. Field installable (Specify **BRK5**; Example: 2.05270.12 BRK5).

## Fork Option

**NSF Listed For Food Service Industry**  
Consult factory for details.

**Swivel Dust Cap**  
(See page 90) (Specify **DC1**; Example: 2.05270.441 DC1).

**Forks Only**  
To order caster forks only use 1st 6 digits of model numbers (Example: 2.02270).

**Axle/Nut Options**  
Consult factory.

## Wheel Selection



See the Performa Advantage on Page 55.

## Wheel Options

**Standard Thread Guards**  
Full thread guards are standard on Precision Polyurethane HI-TECH (9P8) and Performa Crowned Tread (5P8). Partial Thread Guards are standard on Precision

Performa Rubber Flat Tread models (4P8).

**Optional Thread Guards** (See page 98) Available on many models. Specify **TG1** for metal or **TG2** for plastic; Example: 2.05270.441 TG2.

**Prevenz™ Antimicrobial for Medical and Food Service Industries.** This caster wheel additive inhibits the growth of harmful microbes, including bacteria, mold, and fungi. Available for Precision Performa Flat/Crowned and Precision Polyurethane HI-Tech. To order, add "PREV" to the caster number. Example: 2.05270.9P8 PREV.



## Mounting Options

**Standard Mounting (no code necessary):**  
2 1/16" long x 3/4" square with 3 mounting holes 17/64" diameter.

**MTG1:** 7/8" dia square stem 2 1/16" long x w/1 mounting hole 17/64" diameter.

**MTG3:** 3/4" dia. octagon stem 2 1/16" long x w/3 mounting holes 17/64" diameter.

**MTG30:** 1.36" x 2.19; (2 grip rings)

**MTG60:** 3/4" octagon x 2 w/3 holes

To order optional mounting, add mounting code to Swivel Stem Caster Models number (Example: 2.02270.441 MTG1).

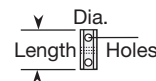

**MTG66:** .858" x 2.06 w/2 holes

**MTG67:** .858" x 2.00" w/1 hole

**MTG57:** 7/8" dia. x 2 1/2" long (2 15/16" dia holes)

**MTG58:** 7/8" x 2 1/2" long (3 15/64" dia. holes)

**Colson 2 Series Casters • Square Stem Swivel & Rigid • Capacity to 350 lbs**

Wheel Dia.	Tread Width	Capacity Each (Pounds)	Wheel Descriptions	Standard Bearings	Swivel Caster Models	Rigid Caster Models	Optional Bearings	Load Height	Swivel Radius	Weight (Pounds)
2 1/2"	1 1/4"	125	Performa Flat Conductive	Ball	2.02270.445COND	—	—	3 3/4"	2 13/32"	1 5/8
		140	Performa Flat	Ball	2.02270.445	—	Delrin (441)	3 3/4"	2 13/32"	1 5/8
		200	Polyolefin	Ball	2.02270.55	—	Delrin (53)	3 3/4"	2 13/32"	1 5/8
		250	Polyurethane Hi-Tech Maroon	Ball	2.02270.95	—	Delrin (91)	3 3/4"	2 13/32"	1 5/8
		250	Polyurethane Hi-Tech Grey	Ball	2.02270.95G	—	Delrin (91G)	3 3/4"	2 13/32"	1 5/8
	300	Cast Iron	Plain	2.02270.12	—	—	—	3 3/4"	2 13/32"	2 1/8
	1 7/16"	300	Phenolic	Roller	2.02270.319	—	—	3 3/4"	2 13/32"	2
3"	1 1/4"	150	Soft Rubber	Plain	2.03370.RR2	—	—	4"	2 21/32"	2
		200	Polyolefin	Ball	2.03370.55	—	Delrin (52)	4"	2 21/32"	2
		200	Performa Flat	Ball	2.03370.445	—	Delrin (441)	4"	2 21/32"	2
		200	Precision Performa Flat	Precision Ball	2.03370.4P8	—	—	4"	2 21/32"	2
		200	Performa Crown	Precision Ball	2.03370.5P8	—	—	4"	2 21/32"	2
		200	Performa Flat Conductive	Ball	2.03370.445COND	—	—	4"	2 21/32"	2
		200	Polyolefin	Ball	2.03370.55	—	Delrin (52)	4"	2 21/32"	2
		300	Polyurethane Hi-Tech Maroon	Ball	2.03370.95	—	Delrin (91)	4"	2 21/32"	2
		300	Polyurethane Hi-Tech Grey	Ball	2.03370.95G	—	Delrin (91G)	4"	2 21/32"	2
		300	Precision Polyurethane Hi-Tech Grey	Precision Ball	2.03370.9P8	—	—	4"	2 21/32"	2
		300	K Solid Polyurethane	Plain	2.03370.KK2	—	—	4"	2 21/32"	2
		300	Cast Iron	Plain	2.03370.14	—	—	4"	2 21/32"	2 3/4
	350	Hard Rubber	Plain	2.03370.RN2	—	—	4"	2 21/32"	2	
		1 15/32"	350	Phenolic	Roller	2.03370.309	—	—	4"	2 21/32"
3 1/2"	1 1/4"	150	Soft Rubber	Plain	2.03270.RR2	—	—	4 9/16"	2 29/32"	2 1/4
		250	Performa Flat	Ball	2.03270.445	—	Delrin (441)	4 9/16"	2 29/32"	2 1/8
		250	Performa Flat Conductive	Ball	2.03270.445COND	—	—	4 9/16"	2 29/32"	2 1/8
		250	Precision Performa Flat	Precision Ball	2.03270.4P8	—	—	4 9/16"	2 29/32"	2 1/8
		250	Performa Crown	Precision Ball	2.03270.5P8	—	—	4 9/16"	2 29/32"	2 1/8
	1 5/16"	250	Performa Round	Ball	2.03270.565	—	Delrin (561)	4 9/16"	2 29/32"	2 1/8
		250	Performa Round Conductive	Ball	2.03270.565COND	—	—	4 9/16"	2 29/32"	2 1/8
	1 1/4"	280	Polyolefin	Ball	2.03270.55	—	Delrin (53)	4 9/16"	2 29/32"	2 1/8
		300	Thermo	Plain	2.03270.52HT	—	—	4 9/16"	2 29/32"	3 1/8
		300	Cast Iron	Plain	2.03270.12	—	—	4 9/16"	2 29/32"	3
		350	Phenolic	Roller	2.03270.309	—	—	4 9/16"	2 29/32"	3
		350	Hard Rubber	Plain	2.03270.RN2	—	—	4 9/16"	2 29/32"	2 1/4
		350	Polyurethane Hi-Tech Maroon	Ball	2.03270.95	—	Delrin (91)	4 9/16"	2 29/32"	1 3/4
		350	Polyurethane Hi-Tech Grey	Ball	2.03270.95G	—	Delrin (91G)	4 9/16"	2 29/32"	1 3/4
		350	Precision Polyurethane Hi-Tech Grey	Precision Ball	2.03270.9P8	—	—	4 9/16"	2 29/32"	1 3/4
4"	1 1/4"	150	Soft Rubber	Plain	2.04270.RR2	—	—	5"	3 29/32"	2 1/4
		300	Performa Flat	Ball	2.04270.445	—	Delrin (441)	5"	3 29/32"	2 1/4
		300	Performa Flat Conductive	Ball	2.04270.445COND	—	—	5"	3 29/32"	2 1/4
		300	Precision Performa Flat	Precision Ball	2.04270.4P8	—	—	5"	3 29/32"	2 1/4
		300	Performa Crown	Precision Ball	2.04270.5P8	—	—	5"	3 29/32"	2 1/4
		300	Thermo	Plain	2.04270.52HT	—	—	5"	3 29/32"	3 1/8
		300	Cast Iron	Plain	2.04270.12	—	—	5"	3 29/32"	3 3/8
		350	Polyolefin	Ball	2.04270.55	—	Delrin (53)	5"	3 29/32"	2 1/8
		350	Polyurethane Hi-Tech Maroon	Ball	2.04270.95	—	Delrin (91)	5"	3 29/32"	2 1/8
		350	Polyurethane Hi-Tech Grey	Ball	2.04270.95G	—	Delrin (91G)	5"	3 29/32"	2 1/8
		350	Precision Polyurethane Hi-Tech Grey	Precision Ball	2.04270.9P8	—	—	5"	3 29/32"	2 1/8
		350	K Solid Polyurethane	Plain	2.04370.KK2	—	—	5"	3 29/32"	2 1/8
	350	Hard Rubber	Plain	2.04270.RN2	—	—	5"	3 29/32"	2 1/4	
	350	Phenolic	Roller	2.04270.309	—	—	5"	3 29/32"	3 3/8	
5"	1 1/4"	175	Soft Rubber	Plain	2.05270.RR2	2.05280.RR2	—	6 1/16"	3 13/16"	3
		300	Cast Iron	Plain	2.05270.12	2.05280.12	—	6 1/16"	3 13/16"	3
		325	Performa Flat	Ball	2.05270.445	2.05280.445	Delrin (441)	6 1/16"	3 13/16"	3
		325	Performa Flat Conductive	Ball	2.05270.445COND	2.05280.445COND	—	6 1/16"	3 13/16"	3
		325	Precision Performa Flat	Precision Ball	2.05270.445	2.05280.445	—	6 1/16"	3 13/16"	3
	1 5/16"	325	Performa Crown	Precision Ball	2.05270.5P8	2.05280.5P8	—	6 1/16"	3 13/16"	3
		325	Performa Round Conductive	Ball	2.05270.565COND	2.05280.565COND	—	6 1/16"	3 13/16"	3
		325	Performa Round	Ball	2.05270.565	2.05280.565	Delrin (561)	6 1/16"	3 13/16"	3
	1 1/4"	350	Hard Rubber	Plain	2.05270.RN2	2.05280.RN2	—	6 1/16"	3 13/16"	3
		350	Polyolefin	Ball	2.05270.55	2.05280.55	Delrin (53)	6 1/16"	3 13/16"	2 3/4
		350	Polyurethane Hi-Tech Maroon	Ball	2.05270.95	2.05280.95	Delrin (91)	6 1/16"	3 13/16"	2 1/2
		350	Polyurethane Hi-Tech Grey	Ball	2.05270.95G	2.05280.95G	Delrin (91G)	6 1/16"	3 13/16"	2 1/2
		350	Precision Polyurethane Hi-Tech Grey	Precision Ball	2.05270.9P8	2.05280.9P8	—	6 1/16"	3 13/16"	2 1/2
		350	K Solid Polyurethane	Plain	2.05370.KK2	2.05380.KK2	—	6 1/16"	3 13/16"	2 1/2
6"	1 1/4"	350	Thermo	Plain	2.05270.52HT	2.05280.52HT	—	6 1/16"	3 13/16"	3 3/4
		350	Phenolic	Roller	2.05270.309	2.05280.309	—	6 1/16"	3 13/16"	3 3/4
		350	Performa Flat	Ball	2.06270.445	—	Delrin (441)	7 1/8"	4 5/16"	3 1/2
		350	Performa Flat Conductive	Ball	2.06270.445COND	—	—	7 1/8"	4 5/16"	3 1/2
		350	Polyurethane Hi-Tech Maroon	Ball	2.06270.95	—	Delrin (91)	7 1/8"	4 5/16"	3
		350	Polyurethane Hi-Tech Grey	Ball	2.06270.95G	—	Delrin (91G)	7 1/8"	4 5/16"	3
		350	Polyolefin	Ball	2.06270.55	—	Delrin (53)	7 1/8"	4 5/16"	3

2 Series

# 2 Series

Capacity up to **350 lbs each**



Consult factory for RoHS requirements on a part specific basis.



Consult the NSF listing page on a part specific basis for NSF requirements.



## Standard Dimensions

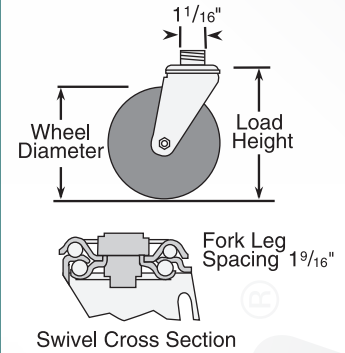

## Features

- Zinc plated finish is attractive and durable
- Full double ball hardened raceways for better performance and greater durability
- 3/8" hollow axle with lock nut
- Grease holes on wheel bearing for greater convenience
- "Colson 45" multi-temp grease lubricates in extreme hot and cold temperatures

## Standard Mounting

- Fits Standard 3/4" NPT Pipe Coupling
- **Stem Size:** approximately 1 1/16" diameter
- The pipe thread stem screws directly into a standard pipe coupling for a rigid and permanent fit with full swivel action

## Easy Installation

- The 7/16" hex nut beneath the lower raceway makes it fast and easy to install these casters on a wide variety of equipment

## Caster Brake



**Top Lock**  
(See page 86) Available on all models with solid axle only. Field installable (Specify **BRK1**; Example: 2.05253.91 BRK1).



**Posi Lock**  
(See page 87) Available on all swivels. Field installable (Specify **BRK8**; Example: 2.05253.9P8BRK8).



**Total Lock**  
(See page 86) Locks wheel and swivel simultaneously. Fits 3 1/2", 4" and 5" models. Field installable (Specify **BRK5**; Example: 2.05253.445 COND BRK5).

## Fork Option

**NSF Listed For Food Service Industry**  
Consult factory for details.

**Swivel Dust Cap**  
(See page 90) (Specify **DC1**; Example: 2.05253.441 DC1).

**Forks Only**  
To order caster forks only use 1st 6 digits of model numbers (Example: 2.02253).

**Axle/Nut Options**  
Consult factory.

## Wheel Selection

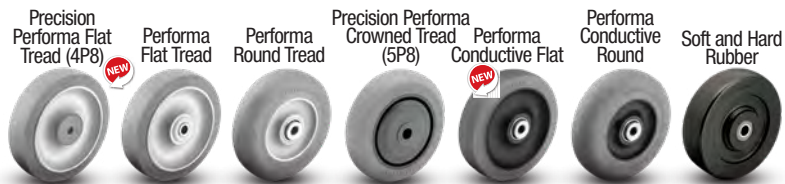

See the Performa Advantage on Page 55.



## Thread Guards

**Standard Thread Guards**  
Full thread guards are standard on Precision Polyurethane Hi-TECH (9P8) and Performa Crowned Tread (5P8). Partial Thread Guards are standard on Precision Performa Rubber Flat Tread models (4P8).

**Optional Thread Guards**  
(See page 98) Available on many models Specify **TG1** for metal or **TG2** for plastic; Example: 2.05253.441 TG2.

**Prevenz™ Antimicrobial for Medical and Food Service Industries.** This caster wheel additive inhibits the growth of harmful microbes, including bacteria, mold, and fungi. Available for Precision Performa Flat/Crowned and Precision Polyurethane Hi-Tech. To order, add "PREV" to the caster number. Example: 2.05253.9P8 PREV.



## Mounting Options

**Standard Mounting (no code necessary):**  
3/4" 14NPT x .62" w/ 7/16" hex mount to fit on standard 3/4" pipe

**MTG23:** 1 1/4" x 7/8" w/1.0" hex

To order optional mounting, add mounting code to Swivel Stem Caster Models number (Example: 2.02253.441 MTG23).

**3D CAD Models & Data Sheets**  
www.colsoncaster.com/casters

Colson 2 Series Casters • Pipe Thread Stem • Capacity to 350 lbs

Wheel Dia.	Tread Width	Capacity Each (Pounds)	Wheel Descriptions	Standard Bearings	Swivel Caster Models	Optional Bearings	Load Height	Swivel Radius	Weight (Pounds)
2 1/2"	1 1/4"	125	Perma Flat Conductive	Ball	2.02253.445COND	-	3 7/8"	2 13/32"	1 5/8
		140	Perma Flat	Ball	2.02253.445	Delrin (441)	3 7/8"	2 13/32"	1 5/8
		200	Polyolefin	Ball	2.02253.55	Delrin (53)	3 7/8"	2 13/32"	1 5/8
		250	Polyurethane Hi-Tech Maroon	Ball	2.02253.95	Delrin (91)	3 7/8"	2 13/32"	1 5/8
		250	Polyurethane Hi-Tech Grey	Ball	2.02253.95G	Delrin (91G)	3 7/8"	2 13/32"	1 5/8
	300	Cast Iron	Plain	2.02253.12	-	-	3 7/8"	2 13/32"	2
	1 7/16"	300	Phenolic	Roller	2.02253.319	-	3 7/8"	2 13/32"	2
3"	1 1/4"	150	Soft Rubber	Plain	2.03353.RR2	-	4 1/8"	2 21/32"	2
		200	Polyolefin	Ball	2.03353.55	Delrin (52)	4 1/8"	2 21/32"	2
		200	Perma Flat	Ball	2.03353.445	Delrin (441)	4 1/8"	2 21/32"	2
		200	Precision Perma Flat	Precision Ball	2.03353.4P8	-	4 1/8"	2 21/32"	2
		200	Perma Crown	Precision Ball	2.03353.5P8	-	4 1/8"	2 21/32"	2
		200	Perma Flat Conductive	Ball	2.03353.445COND	-	4 1/8"	2 21/32"	2
		200	Polyolefin	Ball	2.03353.55	Delrin (52)	4 1/8"	2 21/32"	2
		300	Polyurethane Hi-Tech Maroon	Ball	2.03353.95	Delrin (91)	4 1/8"	2 21/32"	2
		300	Polyurethane Hi-Tech Grey	Ball	2.03353.95G	Delrin (91G)	4 1/8"	2 21/32"	2
		300	Precision Polyurethane Hi-Tech Grey	Precision Ball	2.03353.9P8	-	4 1/8"	2 21/32"	2
		300	K Solid Polyurethane	Plain	2.03353.KK2	-	4 1/8"	2 21/32"	2
		300	Cast Iron	Plain	2.03353.14	-	4 1/8"	2 21/32"	2
		350	Hard Rubber	Plain	2.03353.RN2	-	4 1/8"	2 21/32"	2 3/4
		1 15/32"	350	Phenolic	Roller	2.03353.309	-	4 1/8"	2 21/32"
3 1/2"	1 1/4"	150	Soft Rubber	Plain	2.03253.RR2	-	4 11/16"	2 29/32"	2 1/4
		250	Perma Flat	Ball	2.03253.445	Delrin (441)	4 11/16"	2 29/32"	2
		250	Perma Flat Conductive	Ball	2.03253.445COND	-	4 11/16"	2 29/32"	2
		250	Precision Perma Flat	Precision Ball	2.03253.4P8	-	4 11/16"	2 29/32"	2
		250	Perma Crown	Precision Ball	2.03253.5P8	-	4 11/16"	2 29/32"	2 1/4
	1 5/16"	250	Perma Round	Ball	2.03253.565	Delrin (561)	4 11/16"	2 29/32"	2
		250	Perma Round Conductive	Ball	2.03253.565COND	-	4 11/16"	2 29/32"	2
	1 1/4"	280	Polyolefin	Ball	2.03253.55	Delrin (53)	4 11/16"	2 29/32"	1 7/8
		300	Thermo	Plain	2.03253.52HT	-	4 11/16"	2 29/32"	3
		300	Cast Iron	Plain	2.03253.12	-	4 11/16"	2 29/32"	3
		350	Phenolic	Roller	2.03253.309	-	4 11/16"	2 29/32"	3
		350	Hard Rubber	Plain	2.03253.RN2	-	4 11/16"	2 29/32"	2 1/4
		350	Polyurethane Hi-Tech Maroon	Ball	2.03253.95	Delrin (91)	4 11/16"	2 29/32"	1 7/8
		350	Polyurethane Hi-Tech Grey	Ball	2.03253.95G	Delrin (91G)	4 11/16"	2 29/32"	1 7/8
		350	Precision Polyurethane Hi-Tech Grey	Precision Ball	2.03253.9P8	-	4 11/16"	2 29/32"	1 7/8
4"	1 1/4"	150	Soft Rubber	Plain	2.04253.RR2	-	5 1/8"	3 29/32"	2 1/4
		300	Perma Flat	Ball	2.04253.445	Delrin (441)	5 1/8"	3 29/32"	2 1/4
		300	Perma Flat Conductive	Ball	2.04253.445COND	-	5 1/8"	3 29/32"	2 1/4
		300	Precision Perma Flat	Precision Ball	2.04253.4P8	-	5 1/8"	3 29/32"	2 1/4
		300	Perma Crown	Precision Ball	2.04253.5P8	-	5 1/8"	3 29/32"	2 1/4
		300	Thermo	Plain	2.04253.52HT	-	5 1/8"	3 29/32"	3 1/8
		300	Cast Iron	Plain	2.04253.12	-	5 1/8"	3 29/32"	3 3/8
		350	Polyolefin	Ball	2.04253.55	Delrin (53)	5 1/8"	3 29/32"	2 1/8
		350	Polyurethane Hi-Tech Maroon	Ball	2.04253.95	Delrin (91)	5 1/8"	3 29/32"	2 1/8
		350	Polyurethane Hi-Tech Grey	Ball	2.04253.95G	Delrin (91G)	5 1/8"	3 29/32"	2 1/8
		350	Precision Polyurethane Hi-Tech Grey	Precision Ball	2.04253.9P8	-	5 1/8"	3 29/32"	2 1/8
		350	K Solid Polyurethane	Plain	2.04253.KK2	-	5 1/8"	3 29/32"	2 1/8
		350	Hard Rubber	Plain	2.04253.RN2	-	5 1/8"	3 29/32"	2 1/4
	350	Phenolic	Roller	2.04253.309	-	5 1/8"	3 29/32"	3 3/8	
5"	1 1/4"	175	Soft Rubber	Plain	2.05253.RR2	-	6 3/16"	3 13/16"	3
		300	TPE Hi-Temp	Precision Ball	2.05253.414 H	-	6 3/16"	3 13/16"	3
		300	Cast Iron	Plain	2.05253.12	-	6 3/16"	3 13/16"	2 1/2
		325	Perma Flat	Ball	2.05253.445	Delrin (441)	6 3/16"	3 13/16"	3
		325	Perma Flat Conductive	Ball	2.05253.445COND	-	6 3/16"	3 13/16"	3
		325	Precision Perma Flat	Precision Ball	2.05253.445	-	6 3/16"	3 13/16"	3
		325	Perma Crown	Precision Ball	2.05253.5P8	-	6 3/16"	3 13/16"	3
	1 5/16"	325	Perma Round Conductive	Ball	2.05253.565COND	-	6 3/16"	3 13/16"	3
		325	Perma Round	Ball	2.05253.565	Delrin (561)	6 3/16"	3 13/16"	3
		350	Hard Rubber	Plain	2.05253.RN2	-	6 3/16"	3 13/16"	3
		350	Polyolefin	Ball	2.05253.55	Delrin (53)	6 3/16"	3 13/16"	2 1/2
		350	Polyurethane Hi-Tech Maroon	Ball	2.05253.95	Delrin (91)	6 3/16"	3 13/16"	2 1/2
		350	Polyurethane Hi-Tech Grey	Ball	2.05253.95G	Delrin (91G)	6 3/16"	3 13/16"	2 1/2
		350	Precision Polyurethane Hi-Tech Grey	Precision Ball	2.05253.9P8	-	6 3/16"	3 13/16"	2 1/2
1 1/4"	350	K Solid Polyurethane	Plain	2.05253.KK2	-	6 3/16"	3 13/16"	2 1/2	
	350	Thermo	Plain	2.05253.52HT	-	6 3/16"	3 13/16"	3 3/4	
	350	Phenolic	Roller	2.05253.309	-	6 3/16"	3 13/16"	3 3/4	
6"	1 1/4"	350	Perma Flat	Ball	2.06253.445	Delrin (441)	7 1/4"	4 5/16"	3 1/4
		350	Perma Flat Conductive	Ball	2.06253.445COND	-	7 1/4"	4 5/16"	3 1/4
		350	Polyurethane Hi-Tech Maroon	Ball	2.06253.95	Delrin (91)	7 1/4"	4 5/16"	2 7/8
		350	Polyurethane Hi-Tech Grey	Ball	2.06253.95G	Delrin (91G)	7 1/4"	4 5/16"	2 7/8
		350	Polyolefin	Ball	2.06253.55	Delrin (53)	7 1/8"	4 5/16"	3

2 Series

# 2 Series

Capacity up to 250 lbs each

Convertible Hand Truck



- ### Features
- Zinc plated finish is attractive and durable
  - 3/8" Bolted Axle
  - Features polyolefin thread guard
  - Available with top lock brake
  - Compatible with many different nationally branded convertible hand trucks

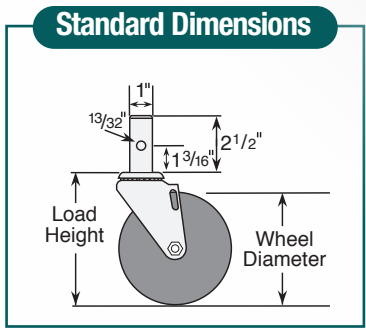

### Standard Mounting

1" x 2 1/2" long stem with one mounting hole, .40" dia.

## Colson 2 Series Casters • Convertible Hand Truck • Capacity to 250 lbs

Wheel Dia.	Tread Width	Capacity Each (Pounds)	Wheel Description	Wheel Bearing	Stem Caster Model	Load Height	Swivel Radius	Weight (Pounds)
5"	1 5/16"	250	TPR (Round)	Centered Precision Ball	2.05551.568	5 7/8"	3 13/16"	2

### Caster Brake



**Top Lock Brake**  
Brake is not field installable (Specify **BRK1**; Example: 2.05551.568 BRK1).

### Wheel Option

**Thread Guards**  
Standard polyolefin thread guard.

# 2 Series

Capacity up to 210 lbs each

LoPro Swivel & Rigid



- ### Features
- Zinc plated finish is attractive and durable
  - Heat treated full double ball hardened raceways
  - Low profile design offers low load height and quick swivel response
  - Ideal for business machines, stock picking carts, warehouse dollies and housekeeping carts
  - Thread guards standard on all models, but are not available with 3" brake option

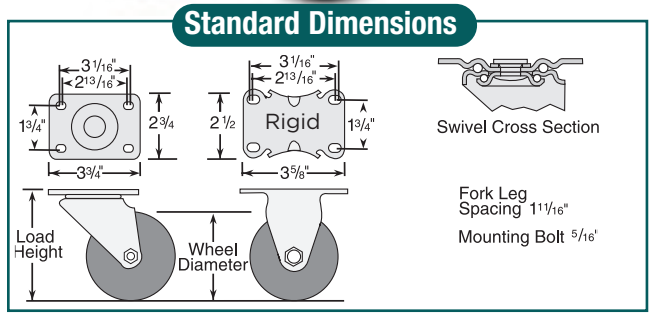

## Colson 2 Series Casters • LoPro Top Plate Swivel & Rigid • Capacity to 210 lbs

Wheel Dia.	Tread Width	Capacity Each (Pounds)	Wheel Descriptions	Wheel Bearing	Swivel Top Plate Caster Models	Rigid Top Plate Caster Models	Load Height	Swivel Radius	Weight (Pounds)
2 1/2"	1 1/8"	120	Cushion Rubber	Nylon*	2.02689.44	2.02688.44	3 5/16"	2 3/8"	1
		175	Hard Rubber	Nylon*	2.02689.54	2.02688.54	3 5/16"	2 3/8"	1
3"	1 1/4"	125	Cushion Rubber	Nylon*	2.03689.44	2.03688.44	3 13/16"	2 11/16"	1 1/2
		210	Hard Rubber	Nylon*	2.03689.54	2.03688.54	3 13/16"	2 11/16"	1 1/2

\*Nylon bearing with powdered metal bushing.

### Caster Brake



**Side Lock**  
(See page 87) Easy to engage and disengage with a touch of the pedal (3" models only). To order specify **BRK3**; Example: 2.03689.54 BRK3.

3D CAD Models & Data Sheets  
www.colsoncaster.com/casters

Swivel & Rigid

# ENCORE®

WHERE ECONOMY MEETS QUALITY

## — Dolly Caster Capacity up to 260 lbs each



www.EncoreCaster.com

Consult factory for RoHS and NSF requirements on a part specific basis.



### Standard Features

- Durable and cost-effective zinc plated finish
- Double ball swivel raceways for better performance and greater strength
- Single insert molded wheel bearing offers smooth rolling and is maintenance free for the life of the dolly
- Unique tread material is non-marking and resists cutting or tearing like other TPR materials
- Applications include moving dollies, medium duty material handling carts, stock carts and more



Encore Dolly

### Caster Brake



#### Top Lock

Brake is not field installable. Available with standard top plate only. Specify "B1" to order with caster.



#### Total Lock

Brake is not field installable. Available with standard top plate only. Specify "B5" to order with caster.

### Standard Dimensions

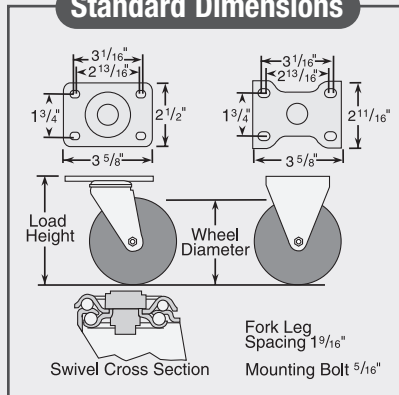

### Optional Top Plate

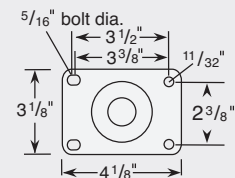

# 59 Top Plate: Available on swivel model only. To order caster with MTG59 top plate, change seventh digit to "9" (Example: E2.D3859.465).

### Encore Dolly Casters • Top Plate Swivel & Rigid • Capacity to 260 lbs

Wheel Dia.	Tread Width	Capacity Each (Pounds)	Wheel Descriptions	Swivel Top Plate Caster Models	Rigid Top Plate Caster Models	Load Height	Swivel Radius	Weight lbs (Rigid Deduct 1 lbs.)
3"	1 1/4"	180	TPR (Flat/Grey)	E2.D3856.465	E2.D3808.465	4 1/8"	2 19/32"	1 5/8
3 1/2"	1 1/4"	200	TPR (Flat/Grey)	E2.D3756.465	E2.D3708.465	4 11/16"	2 27/32"	1 7/8
4"	1 1/4"	240	TPR (Flat/Grey)	E2.D4756.465	E2.D4708.465	5 1/8"	3 11/32"	2
5"	1 1/4"	260	TPR (Flat/Grey)	E2.D5756.465	E2.D5708.465	6 3/16"	3 13/16"	2 1/4

# 2 Series

Capacity up to **325 lbs each**

**STAINLESS STEEL** Swivel & Rigid



www.ColsonCaster.com



Consult factory for RoHS requirements on a part specific basis.

Consult the NSF listing page on a part specific basis for NSF requirements.

## Features

- Polished 304 grade stainless steel construction handles the most punishing, corrosive conditions
- Double ball raceways for better performance and greater durability
- All component parts, including spanner bushing, axle and nut are stainless steel
- Designed to perform in the most hostile environments
- If rust is a problem... Colson stainless steel is the solution



## Standard Dimensions

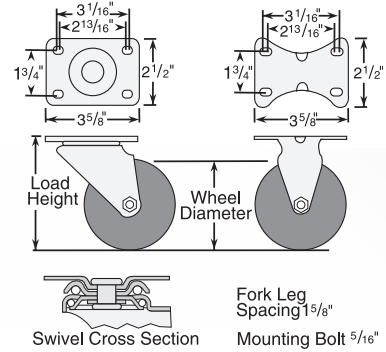

## Colson 2 Series Casters • Stainless Steel Top Plate Swivel & Rigid • Capacity to 325 lbs

Wheel Dia.	Tread Width	Capacity Each (Pounds)	Wheel Descriptions	Wheel Bearing	Swivel Top Plate Caster Models	Rigid Top Plate Caster Models	Load Height	Swivel Radius	Weight (Pounds)
3"	1 1/4"	150	Rubber HI-TECH	Plain	2.33456.42	2.33408.42	4 1/4"	3 1/8"	1 5/8
		200	Polyolefin	Delrin	2.33456.544	2.33408.544	4 1/4"	3 1/8"	1 5/8
			Polyurethane HI-TECH	Plain	2.33456.944	2.33408.944	4 1/4"	3 1/8"	1 5/8
3 1/2"	1 1/4"	250	Polyolefin	Delrin	2.03456.544	2.03408.544	4 11/16"	3 3/8"	1 5/8
			Polyurethane HI-TECH	Delrin	2.03456.944	2.03408.944	4 11/16"	3 3/8"	1 7/8
			Perma Rubber (Flat)	Delrin	2.03456.444	2.03408.444	4 11/16"	3 3/8"	1 3/4
		Thermo	Plain	2.03456.52 HT	2.03408.52 HT	4 11/16"	3 3/8"	1 5/8	
	1 5/16"	210	Perma Rubber (Round)	Delrin	2.03456.564	2.03408.564	4 11/16"	3 3/8"	1 3/4
4"	1 1/4"	250	ThermoTech	Teflon	2.04456.613 H	2.04408.613 H	5 1/8"	3 5/16"	3
		275	Polyolefin	Delrin	2.04456.544	2.04408.544	5 1/8"	3 5/16"	2 1/8
			Polyurethane HI-TECH	Delrin	2.04456.944	2.04408.944	5 1/8"	3 5/16"	2 1/8
		300	Perma Rubber (Flat)	Delrin	2.04456.444	2.04408.444	5 1/8"	3 5/16"	2 1/4
			Thermo	Plain	2.04456.52 HT	2.04408.52 HT	5 1/8"	3 5/16"	2 1/4
5"	1 1/4"	250	ThermoTech	Teflon	2.05456.613 H	2.05408.613 H	6 3/16"	4 1/16"	3
		300	Polyolefin	Delrin	2.05456.544	2.05408.544	6 3/16"	4 1/16"	2 5/8
			Polyurethane HI-TECH	Delrin	2.05456.944	2.05408.944	6 3/16"	4 1/16"	2 5/8
		325	Perma Rubber (Flat)	Delrin	2.05456.444	2.05408.444	6 3/16"	4 1/16"	2 3/4
	Thermo	Plain	2.05456.52 HT	2.05408.52 HT	6 3/16"	4 1/16"	2 3/4		
1 5/16"	250	Perma Rubber (Round)	Delrin	2.05456.564	2.05408.564	6 3/16"	4 1/16"	2 3/4	

**Hollow Kingpin:** available by special order only; consult factory

## Wheel Selection



## Fork Option

**NSF Listed For Food Service Industry**  
Available on all models (Specify **FSI**;  
Example: 2.05456.444 FSI).

### Forks Only

To order caster forks only use 1st 6 digits of model numbers (Example: 2.33456).

## Caster Brake



### Top Lock

(See page 86) Available on all swivel models. Not recommended for high-temp applications. Field installable (Specify **BRK1**; Example: 2.05456.944 BRK1).



### Tech Lock

(See page 87) Available on 4" and 5" swivel models. Field installable (Specify **BRK2**; Example: 2.05456.544 BRK2).



### Total Lock

(See page 86) Riveted design is not field installable. Locks wheel and swivel. Available on all swivel models (Specify **BRK4**; Example: 2.05456.944 BRK4).

**3D CAD Models & Data Sheets**  
www.colsoncaster.com/casters

# 2 Series

STAINLESS STEEL PRECISION

Capacity up to **300 lbs each**

Swivel & Rigid



Consult factory for RoHS requirements on a part specific basis.



Consult the NSF listing page on a part specific basis for NSF requirements.

2 Series

## Features

- Ergonomically friendly and durable stainless steel precision bearing swivel raceway for maximum roll and swivel ease
- All component parts stainless steel to handle the most punishing, corrosive conditions
- Maintenance free, permanently sealed, precision bearing in metal housing
- 5/32" stainless steel top plate for maximum durability
- High impact strength

## Typical Applications

- Typical applications include medical applications, autoclave operations or where wash down of equipment is required



## Standard Dimensions

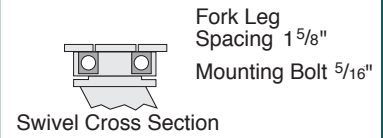
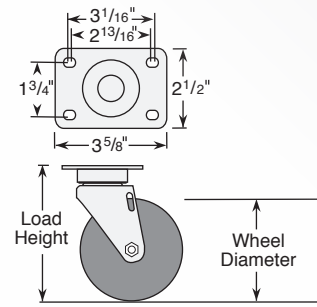

## Precision Raceway Advantage:

- *Quieter than conventional casters*
- *Smooth and easy turning*
- *Ergonomic: less force to push & pull*

## Colson 2 Series Casters • Stainless Steel Precision • Capacity to 300 lbs

Wheel Dia.	Tread Width	Capacity Each (Pounds)	Wheel Descriptions	Wheel Bearing	Swivel Top Plate Caster Models	Rigid Top Plate Caster Models	Load Height	Swivel Radius	Weight (Pounds)
5"	1 1/4"	275	Polyolefin	Delrin	2.X5456.544	2.05408.544	6 3/16"	3 13/16"	2 5/8
			Polyurethane HI-TECH	Delrin	2.X5456.944	2.05408.944	6 3/16"	3 13/16"	2 5/8
		300	Performa Rubber (Flat)	Delrin	2.X5456.444	2.05408.444	6 3/16"	3 13/16"	2 3/4

## Wheel Selection

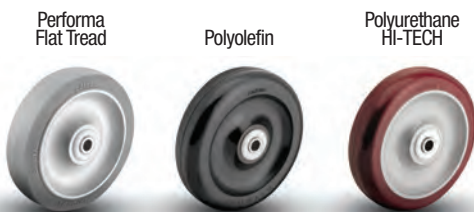

See the Performa Advantage on Page 55.

## Fork Option

### NSF Listed For Food Service Industry

Available on all models (Specify FSI; Example: 2.X5456.544 FSI).

### Forks Only

To order caster forks only, use 1st 6 digits of model numbers (Example: 2.X5456).